

C 542

**COMPACT
DISC PLAYER**

C 542

**COMPACT
DISC PLAYER**

SERVICE MANUAL

NAD

SAFETY INFORMATION

CAUTION

CAUTION - INVISIBLE LASER RADIATION WHEN OPEN AND INTERLOCKS DEFEATED. AVOID EXPOSURE TO BEAM.

ADVARSEL - USYNLIG LASERSTRÅLING NÅR DEKSEL ÅPNES OG SIKKERHEDSLÅS BRYTES. UNNGÅ EKSPONERING FOR STRÅLEN.

ADVARSEL - USYNLIG LASERSTRÅLING VED ÅBNING, NÅR SIKKERHEDSAFBRYDERE ER UDE AF FUNKTION. UNDGÅ UDSÆTTELSE FOR STRÅLING.

VARING - OSYNLIG LASERSTRÅLNING NÅR DENNA DEL ÄR ÖPPNAD OCH SPÄRRAR ÄR URKOPPLADE. STRÅLEN ÄR FARLIG.

VARO! - AVATTAESSA JA SUOJALUKITUS OHITETTAESSA OLET ALTTIINA NÄKTMÄTÖNTÄ LASERSÄTEILYLLE. ÄLÄ KAISO SÄTEESEEN.

VORSICHT! - UNSICHTBARE LASERSTRAHLUNG TRITTT AUS, WENN DECKEL GEÖFFNET UND WENN SICHERHEITVERRIEGELUNG ÜBERBRÜCKT IST. NICHT DEM STRAHL AUSSETZEN.

**CLASS 1
LASER PRODUCT**

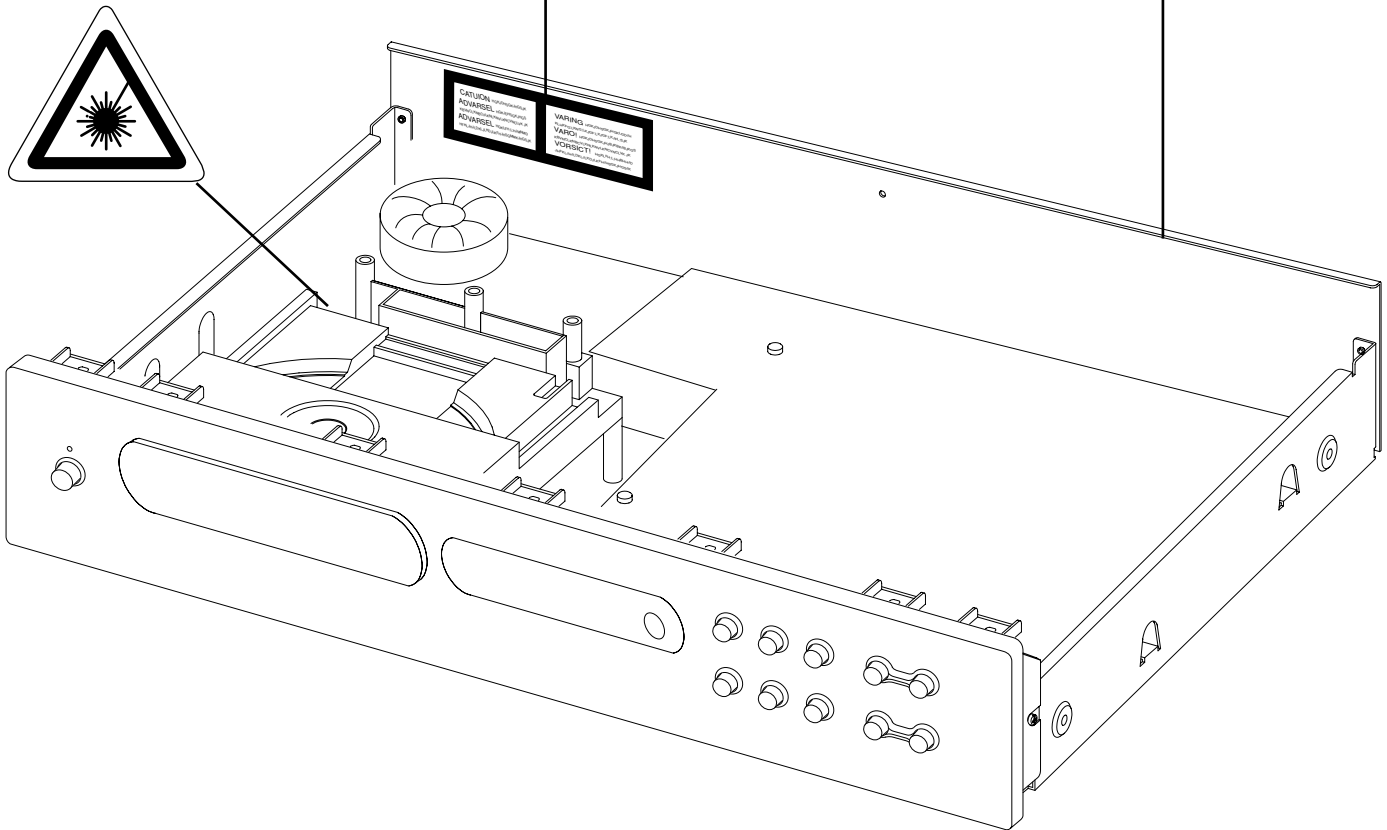

The lightning flash with arrowhead, within an equilateral triangle is intended to alert the user of the presence of uninsulated "dangerous voltage" within the product's enclosure; that may be of sufficient magnitude to constitute a risk of electric shock to persons.



The exclamation point within an equilateral triangle is intended to alert the user of the presence of important operating and maintenance (servicing) instructions in the literature accompanying the appliance.

THIS DEVICE COMPLIES WITH PART 15 OF THE FCC RULES. OPERATION IS SUBJECT TO THE FOLLOWING TWO CONDITIONS:-
(1) THIS DEVICE MAY NOT CAUSE HARMFUL INTERFERENCE, AND
(2) THIS DEVICE MUST ACCEPT ANY INTERFERENCE RECEIVED, INCLUDING INTERFERENCE THAT MAY CAUSE UNDESIRED OPERATION.

SERVICE SAFETY PRECAUTIONS

1. Replacing the fuses

CAUTION: FOR CONTINUED PROTECTION AGAINST THE RISK OF FIRE REPLACE ONLY WITH SAME TYPE OF FUSE.

Reference No		Part Number	Description
M507	*AH \triangle	5120-0052-0	FUSE T1.6A 250V 5x20MM
M507	*C \triangle	5120-0050-0	FUSE T1.6A 250V 5x20MM
M512, M513	*AH \triangle	5120-0020-0	FU T1A 250V UL/CSA 5x20MM
M512, M513	*C \triangle	5120-0018-0	FU T1A 250V SEMKO/VDE
M514	*AH \triangle	5120-0026-0	FU T315MA L 250V UL/CSA
M514	*C \triangle	5120-0027-0	FU T315MA L 250V

NOTE:

<*AH > : USA, CANADIAN MODEL ONLY.

<*C > : EUROPEAN MODEL ONLY.

2. Safety check out

(Only U.S.A. model)

Before returning the product to the customer, make leakage current or resistance measurements to determine that exposed parts are acceptably insulated from the supply circuit.

Parts marked with the symbol \triangle are critical with regard to the risk of fire and electric shock. Replace only with parts recommended by the manufacturer.

CONTENTS

DESCRIPTION	PAGE
SPECIFICATIONS	4
REAR PANEL / FRONT PANEL	5
DISASSEMBLY INSTRUCTIONS	6
BLOCK DIAGRAM	7
WIRING DIAGRAM	8
RF PATTERN TESTING	9
IMPORTANT NOTES	10-11
PCB LAYOUT	12-13
SCHEMATIC DIAGRAM	14-18
IC BLOCK DIAGRAM	19-22
TROUBLESHOOTING GUIDE	23
ELECTRICAL PARTS LIST	24-29
MECHANISM EXPLODED VIEW	30
MECHANISM EXPLODED VIEW PARTS LIST	31
EXPLODED VIEW	32
EXPLODED VIEW PARTS LIST	33-34
PACKING DIAGRAM	35

SPECIFICATIONS

Disc Capacity	One Disc, 120 or 80 mm
Decoding	BURR-BROWN Delta Sigma 24bit
Digital Filter	8 Times oversample
Analog Filter	4 pole active
Frequency Response	+/- 0.5 dB, 5Hz - 20kHz
De-Emphasis Error	+/- 0.3 dB
THD (at 0 dB, 1kHz)	0.002%
Intermodulation Distortion	< - 100 dB
(19 + 20 kHz)	
Dynamic Range	96 dB
Linearity	+/- 0.5 dB, 0 dB to -80 dB
Signal / Noise Ratio (A-Weight)	≥100 dB, De-Emphasis on ≥100 dB, De-Emphasis off
Channel Separation 1kHz	>90 dB
10 kHz	>80 dB
Wow and Flutter	Unmeasurable (Quartz Crystal Accuracy)
Output Impedance	200 Ω
Output Level at 0 dB	2.2 V rms
Digital Error Correction	IRC with double error correction in C1 and C2
Digital Code Output	Sony / Philips Serial data format
Power Consumption	12W

CONTROLS

Play / Pause, Stop, Random, Skip (< >), Scan (< >), Open, Time, Repeat.

PHYSICAL SPECIFICATIONS

Dimensions (Width x Height x Depth)	435 x 80 x 285 mm
Net weight	4 kg (8.8 lbs)
Shipping weight	5.1 kg (11.22 lbs)

REAR PANEL / FRONT PANEL

REAR PANEL

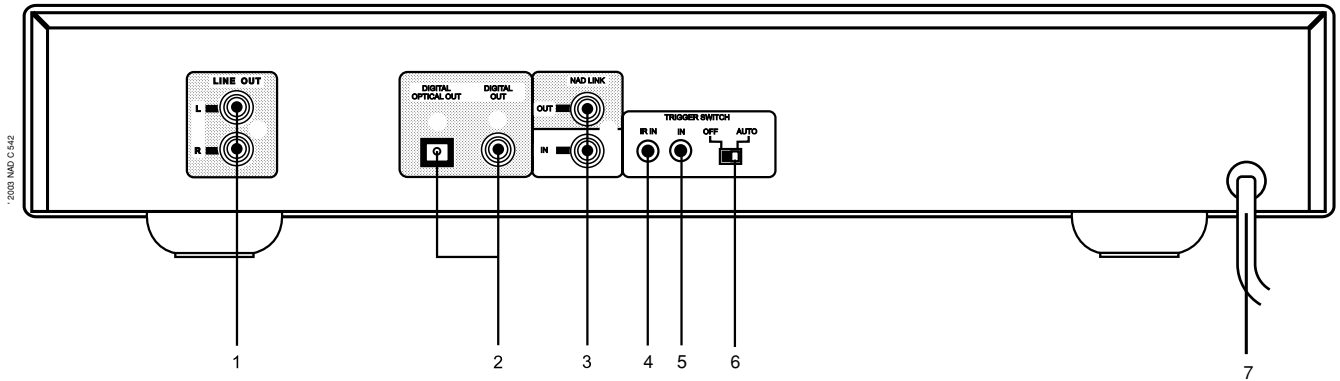

- | | |
|-------------------------------------|-------------------|
| 1. LINE OUT | 5. TRIGGER IN |
| 2. DIGITAL OPTICAL & COAXIAL OUTPUT | 6. TRIGGER SWITCH |
| 3. NAD LINK IN / OUT | 7. AC LINE CORD |
| 4. IR INPUT | |

FRONT PANEL

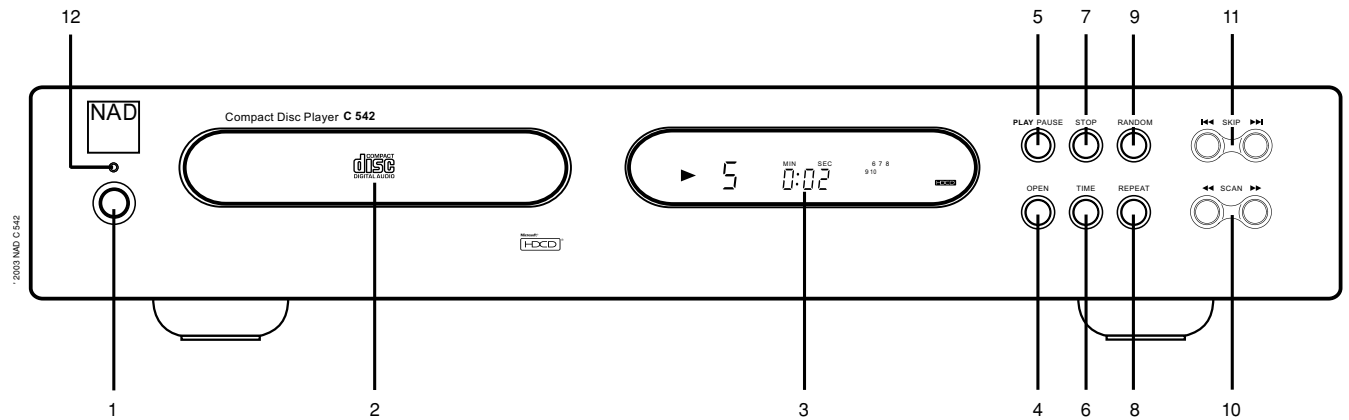

- | | |
|-------------------|-------------------------------------|
| 1. POWER ON / OFF | 7. STOP |
| 2. DISC DRAWER | 8. REPEAT |
| 3. DISPLAY | 9. RANDOM |
| 4. OPEN | 10. SCAN Back (◀◀) / Forward (▶▶) |
| 5. PLAY / PAUSE | 11. SKIP Back (◀◀◀) / Forward (▶▶▶) |
| 6. TIME | 12. STANDBY LED |

DISASSEMBLY INSTRUCTIONS

1. Remove machine screws M 4.0 x 6.0 (① to ④) from the side panels.
Remove tapping screw 3.0 x 8.5 (⑤) from the back panel.
Refer to **Figure No.1**.

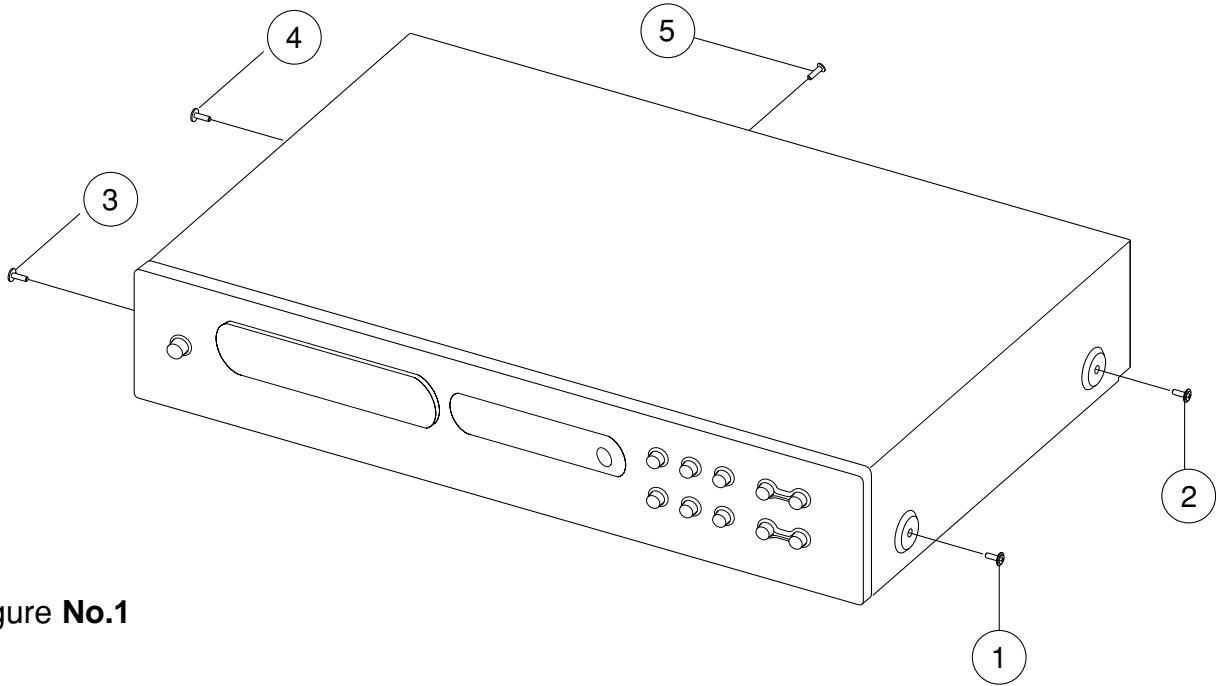

Figure No.1

2. Pull both sides of the TOP COVER slightly outwards (⑥) and tilt approx. 35° and then remove in the direction as indicated by the arrow (⑦). Refer to **Figure No.2**.

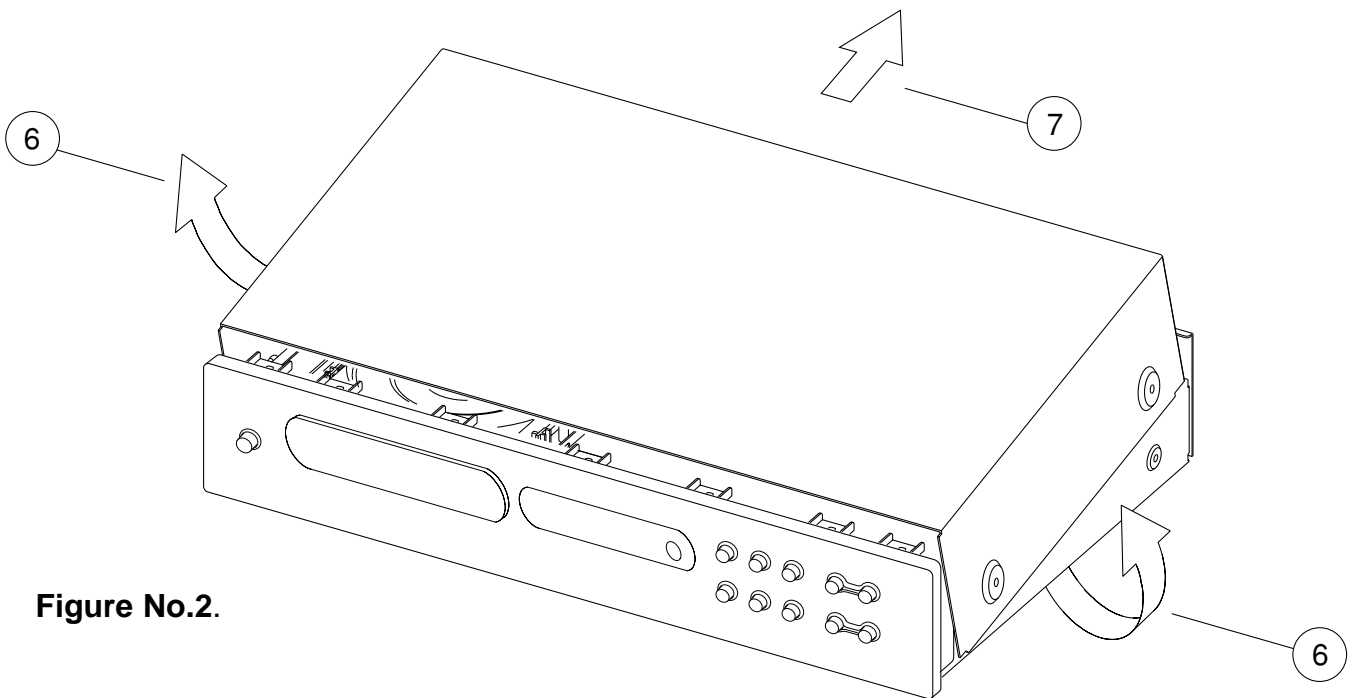
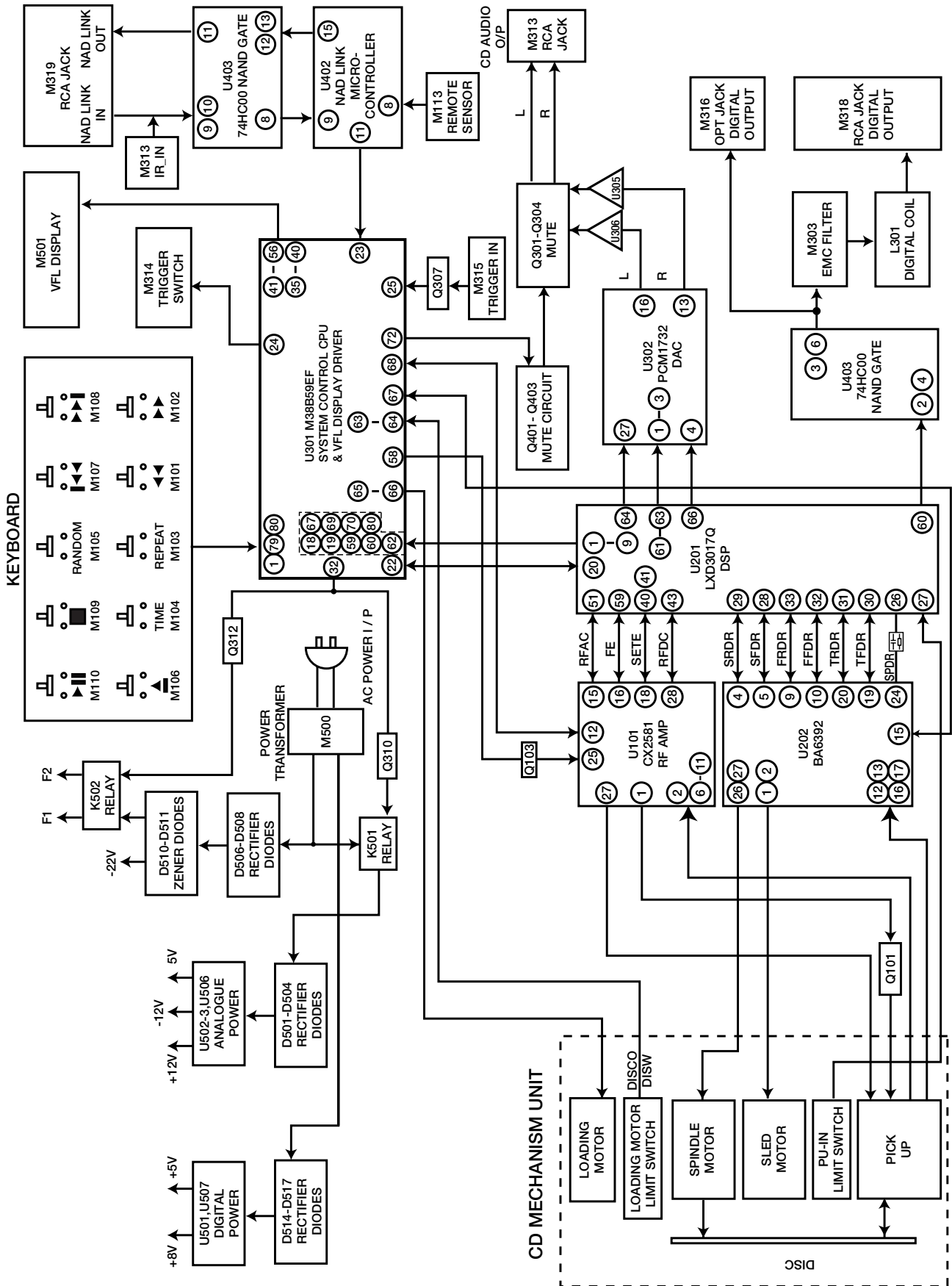
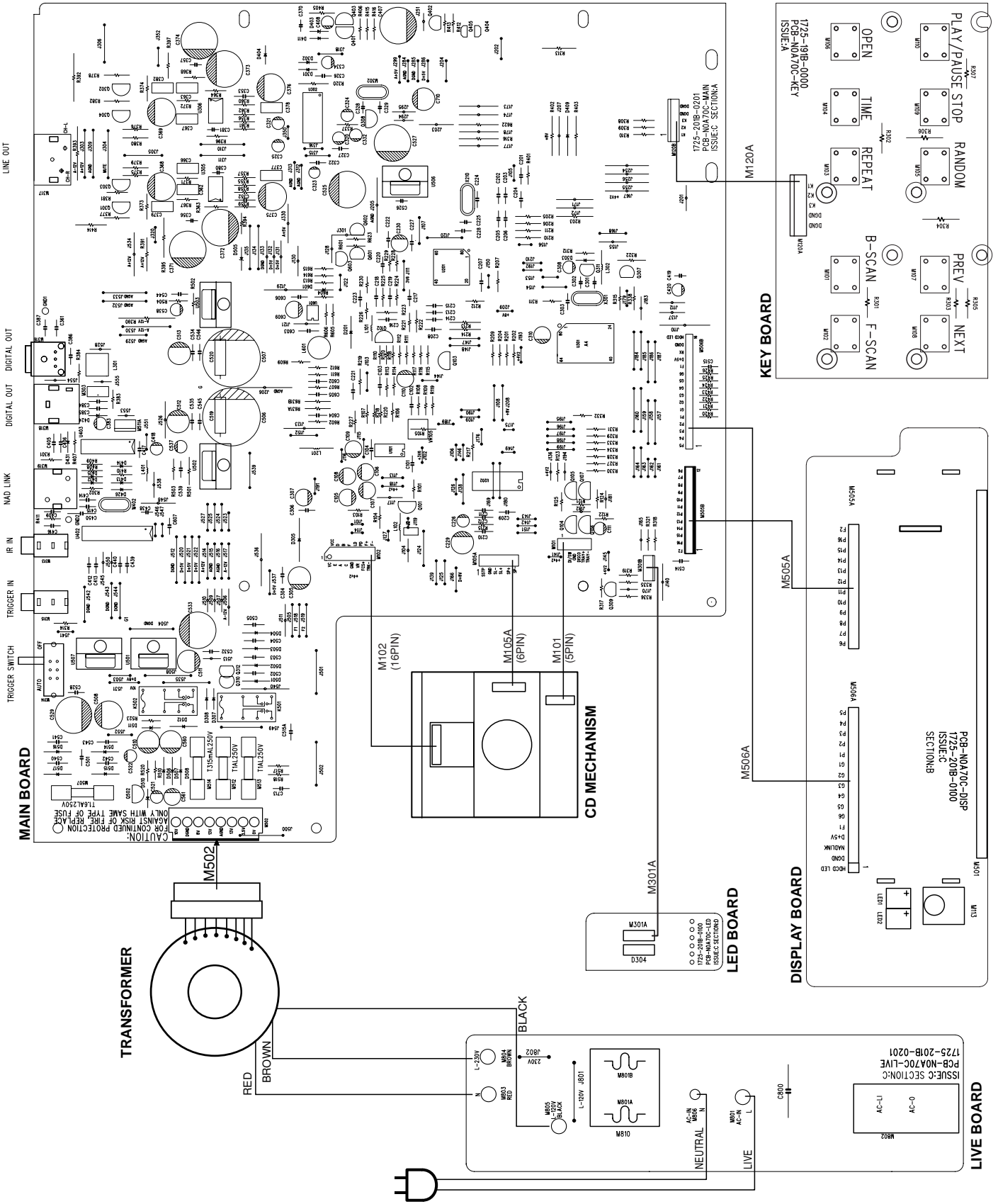

Figure No.2.

BLOCK DIAGRAM



WIRING DIAGRAM



RF PATTERN TESTING

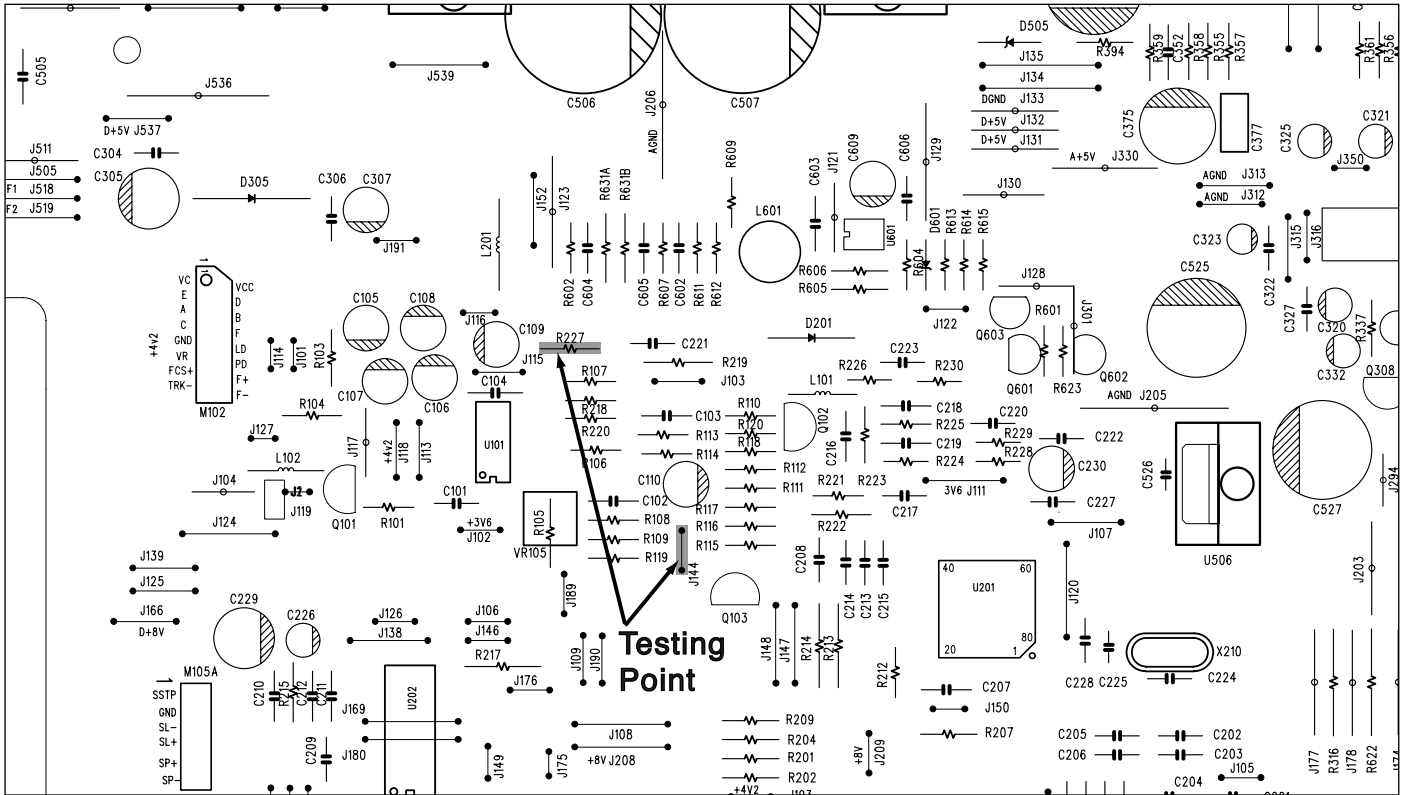

NAD - C 542 PCB TESTING POINTS DIAGRAM

TESTING PROCEDURE

- Load the test disc (Sony Test CD YEDS-7) and set the unit into PLAY mode.
- Connect the scope to R227 (Pin 15 of U101) and DGND (J144).
Scope setting: Coupling : AC.
Vertical sensitivity : 0.2 V/ div.
Horizontal time base : 0.5 μ S/div.
- Observe the waveform is 2.0V p-p +/-5% and the eye pattern is at its best shape (see FIG. 1).

FIG. 1 (a)

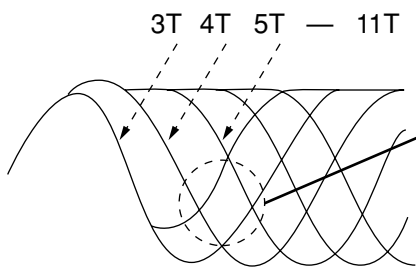

FIG. 1 (b) Poor eye pattern

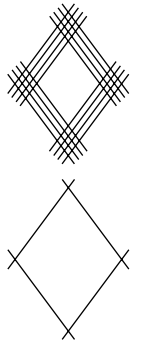

FIG. 1 (C) Good eye pattern

IMPORTANT NOTES

INSTRUCTION FOR HANDLING OPTICAL SYSTEM BLOCK PICK-UP

Electrostatic breakdown of the laser diode in the optical system block may occur due to a potential difference caused by electrostatic charge accumulated on clothing, human body, etc. A ground must be provided as follows to prevent any electrostatic charge during unpacking or repair work.

1. Ground for Human Body

Be sure to wear a ground band (1M ohm) that is properly to remove any static electricity that may be charged on the body.

2. Ground for Work Bench

Be sure to place a conductive sheet (1M ohm) or copper plate with proper grounding on the work bench or other surface on which the pick-up is to be placed.

3. Because the static electricity charge on the clothing does not discharge through the body grounding band, do not let clothing get in contact with the pick-up unit.

INCORRECT

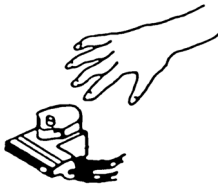

CORRECT

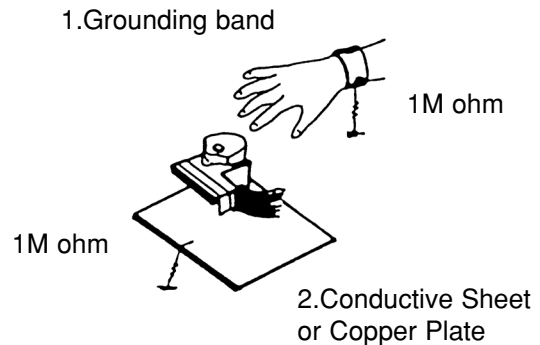

NOTE: Laser diodes are so susceptible to damage from static electricity that even if a static discharge does not ruin the diode, it can shorten its life or cause it to work improperly.

PRECAUTIONS FOR CHECKING BEAM EMISSION

The laser beam of this unit is focused on the reflecting surface of the objective lens in the optical system block. Therefore, keep your eyes at least 12 inches (30 cm) away from the objective lens when the laser diode is **ON**. (Operation Check Method for Laser Diode and Focus Search Function.)

When the **POWER** switch is turned **ON** after the chucking plate is removed, observe the objective lens and confirm that the following operations are performed properly.

(The optical system should be at the lead-in area position when it is checked at this time.)

- (1) The laser should be at the innermost position after the chucking plate is removed.
- (2) The diffused light of the laser beam can be seen when the **POWER** switch is turned **ON**.
- (3) Vertical (up and down) movement of the objective lens (2 or 3 times) will take place.

PRECAUTIONS WHEN CHANGING LASER PICK-UP

When removing the pick-up assembly, short circuit the PCB tracks on the optical block as show in the drawing in order to protect the pick-up before removal.

NOTE: Replacement pick-up assemblies are supplied with the PCB pattern already protected.

DO NOT REMOVE THE SHORT CIRCUITS UNTIL YOU HAVE FINISHED FITTING THE PICK-UP.

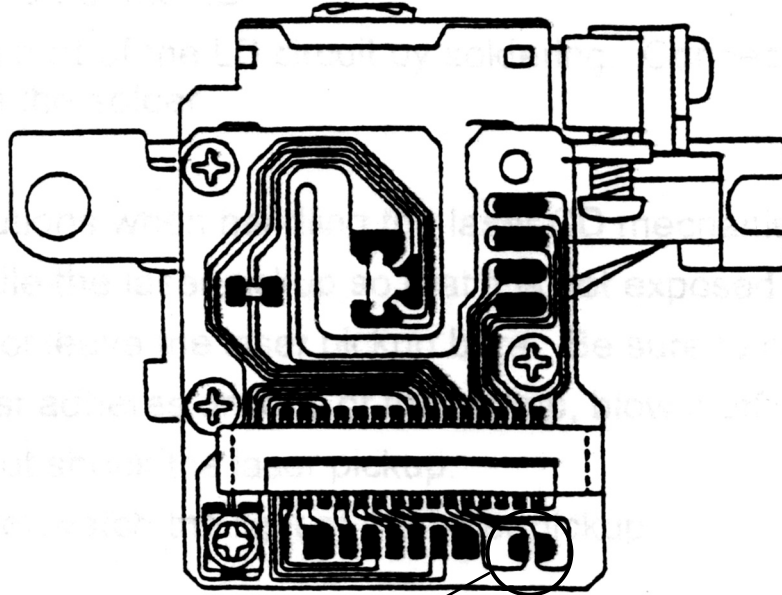

Protective soldering place
for laser diode

Caution:

Laser diodes are extremely susceptible to damage from static electricity. Even if a static discharge does not ruin the diode, it can shorten its life or cause it to work improperly. When replacing the pick-up, use a conductive mat, a grounded soldering iron, and so on, to protect the laser diode from static damage.

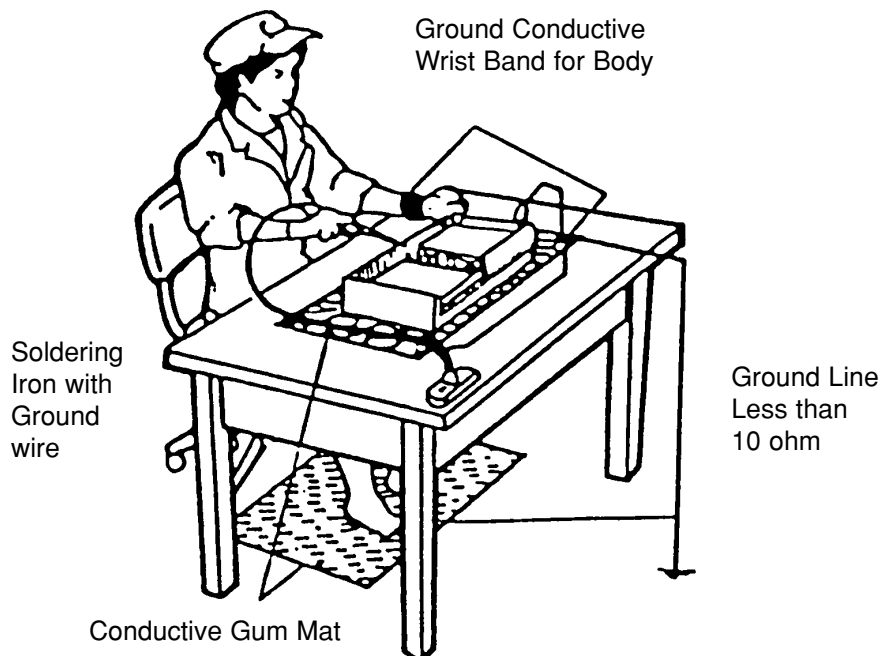

PCB LAYOUT

DISPLAY BOARD

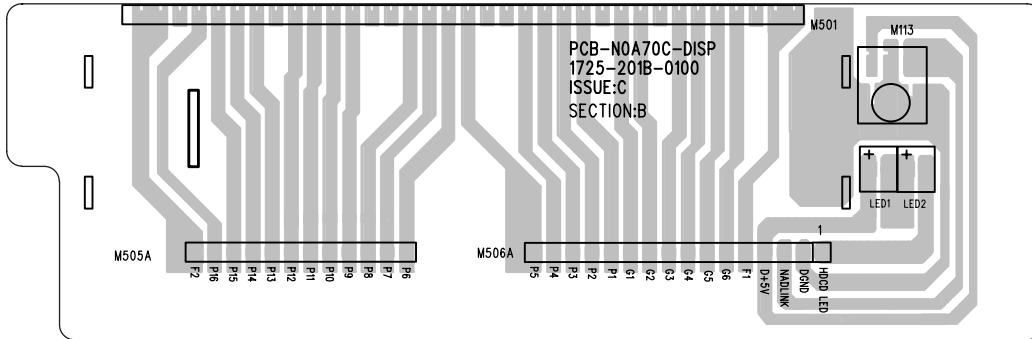

KEY BOARD

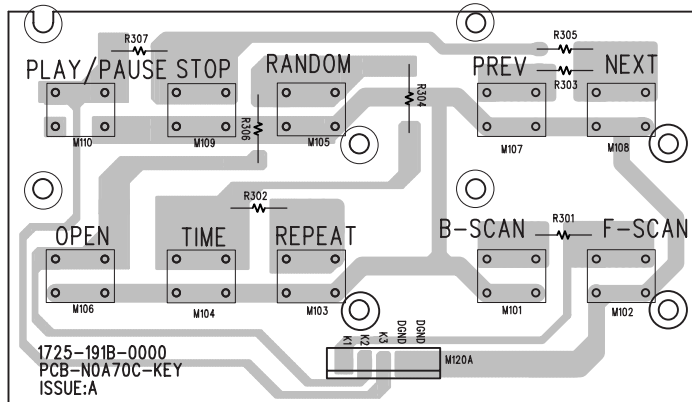

LIVE BOARD

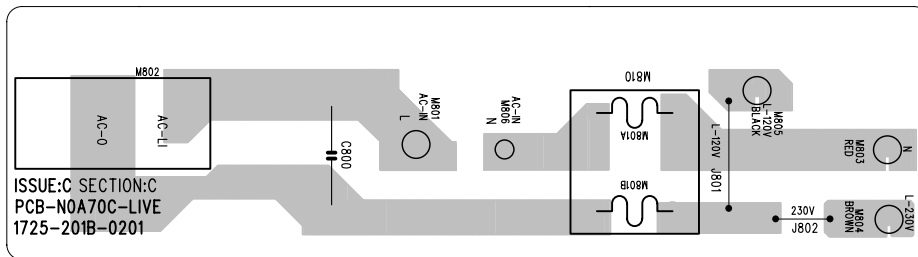

LED BOARD

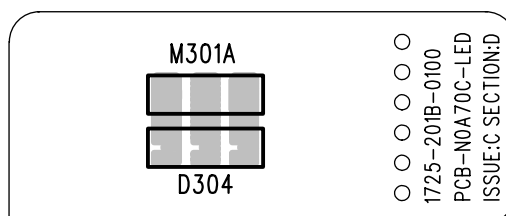

MAIN BOARD

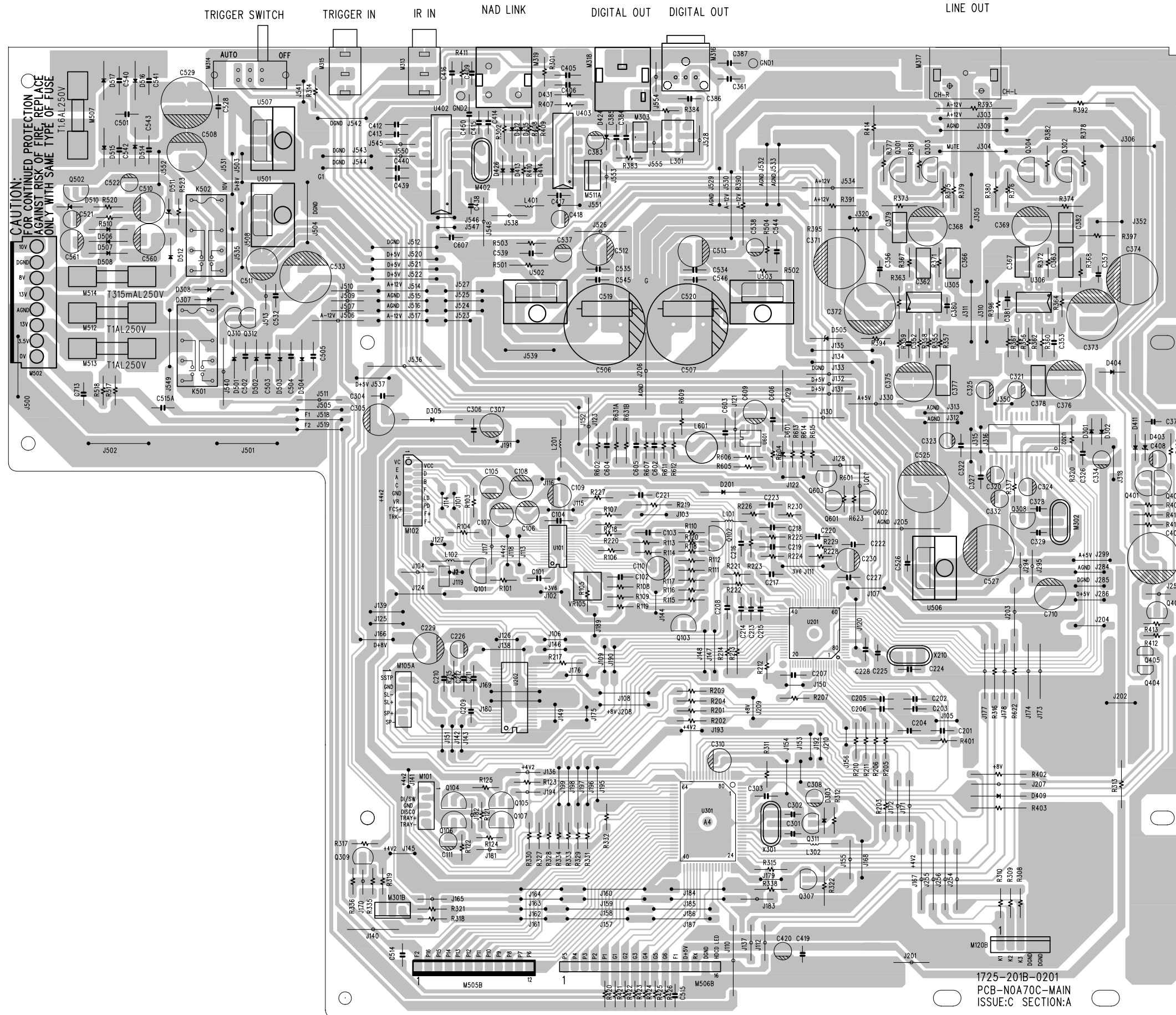

SCHEMATIC DIAGRAM

MCU

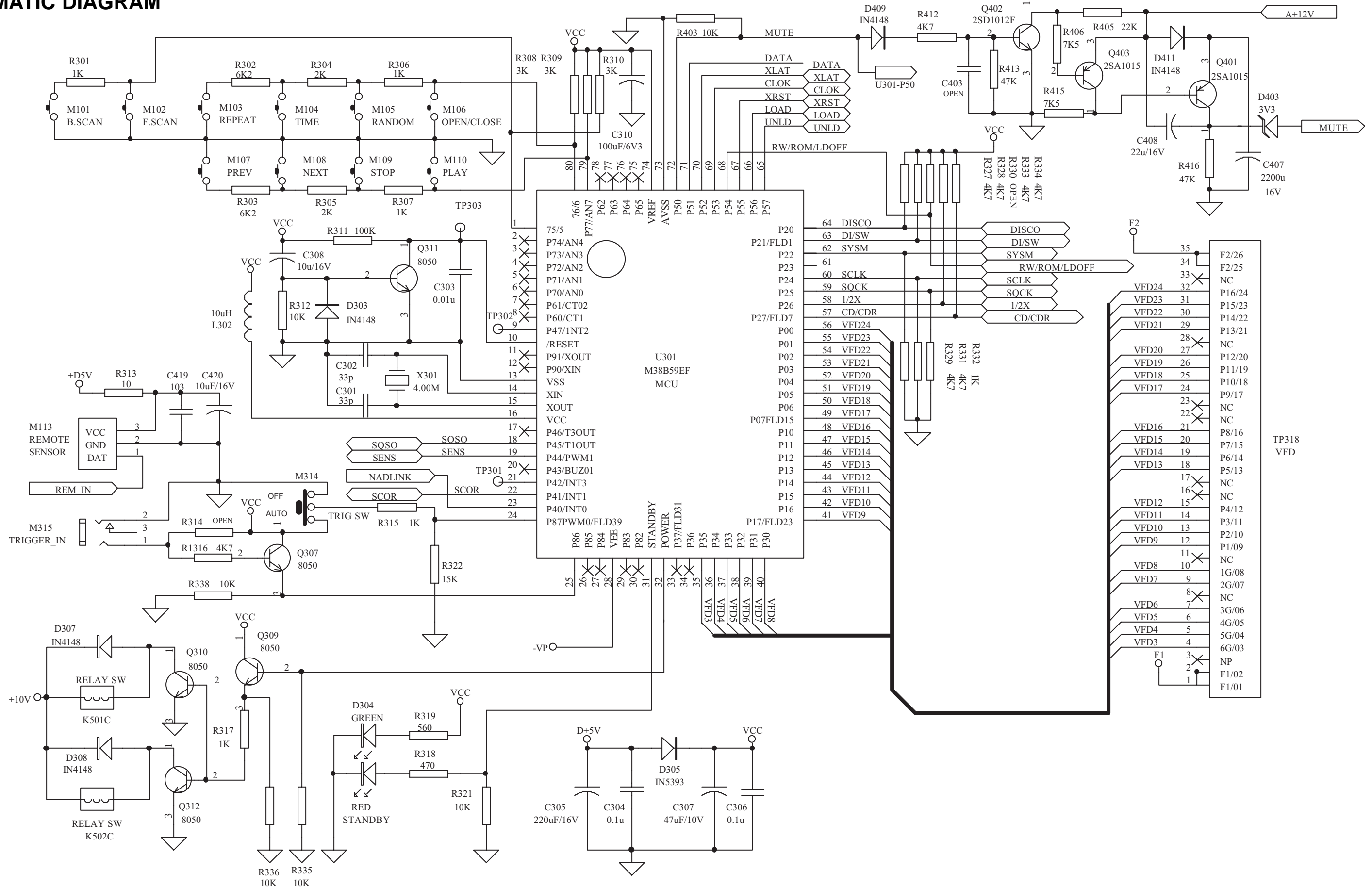

DISPLAY

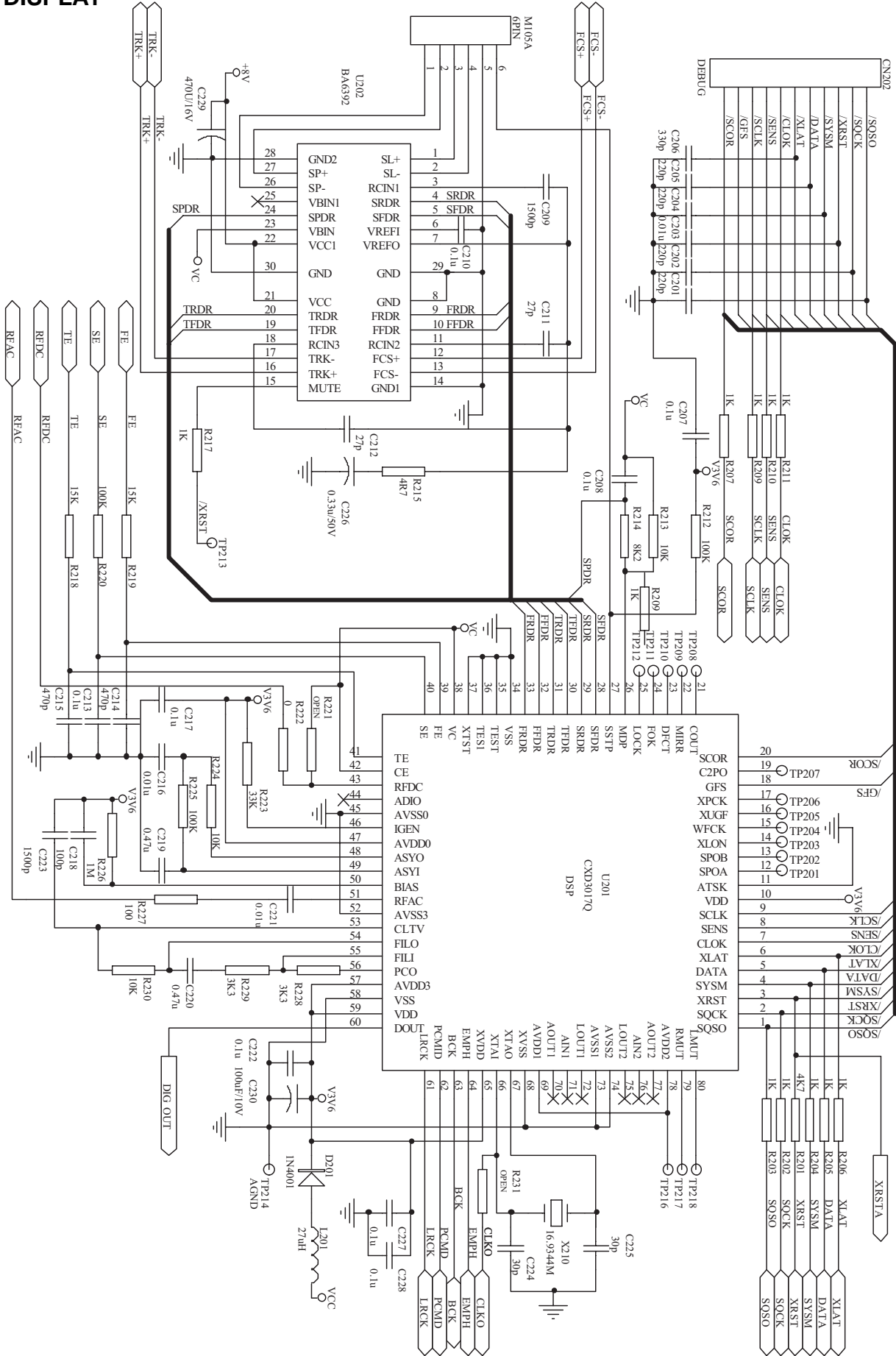

NOTE: 1. RESISTORS ARE CARBON FILM 5% 1/8W UNLESS OTHERWISE SPECIFIED.
 2. CERAMIC CAPACITORS, ARE 50V 10% UNLESS OTHERWISE SPECIFIED.

RF AMP

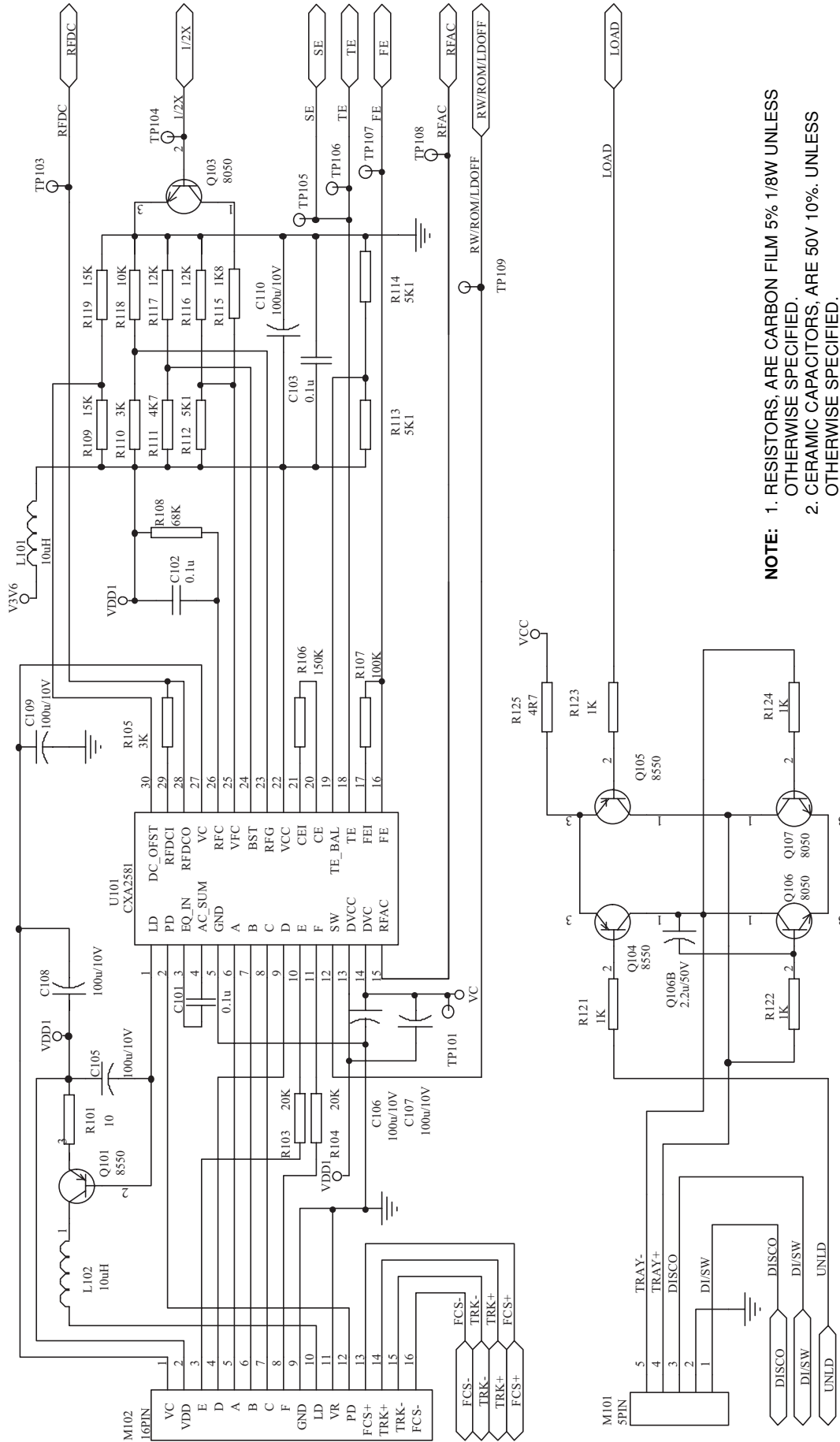

NOTE: 1. RESISTORS, ARE CARBON FILM 5% 1/8W UNLESS OTHERWISE SPECIFIED.
 2. CERAMIC CAPACITORS, ARE 50V 10%. UNLESS OTHERWISE SPECIFIED.

DAC

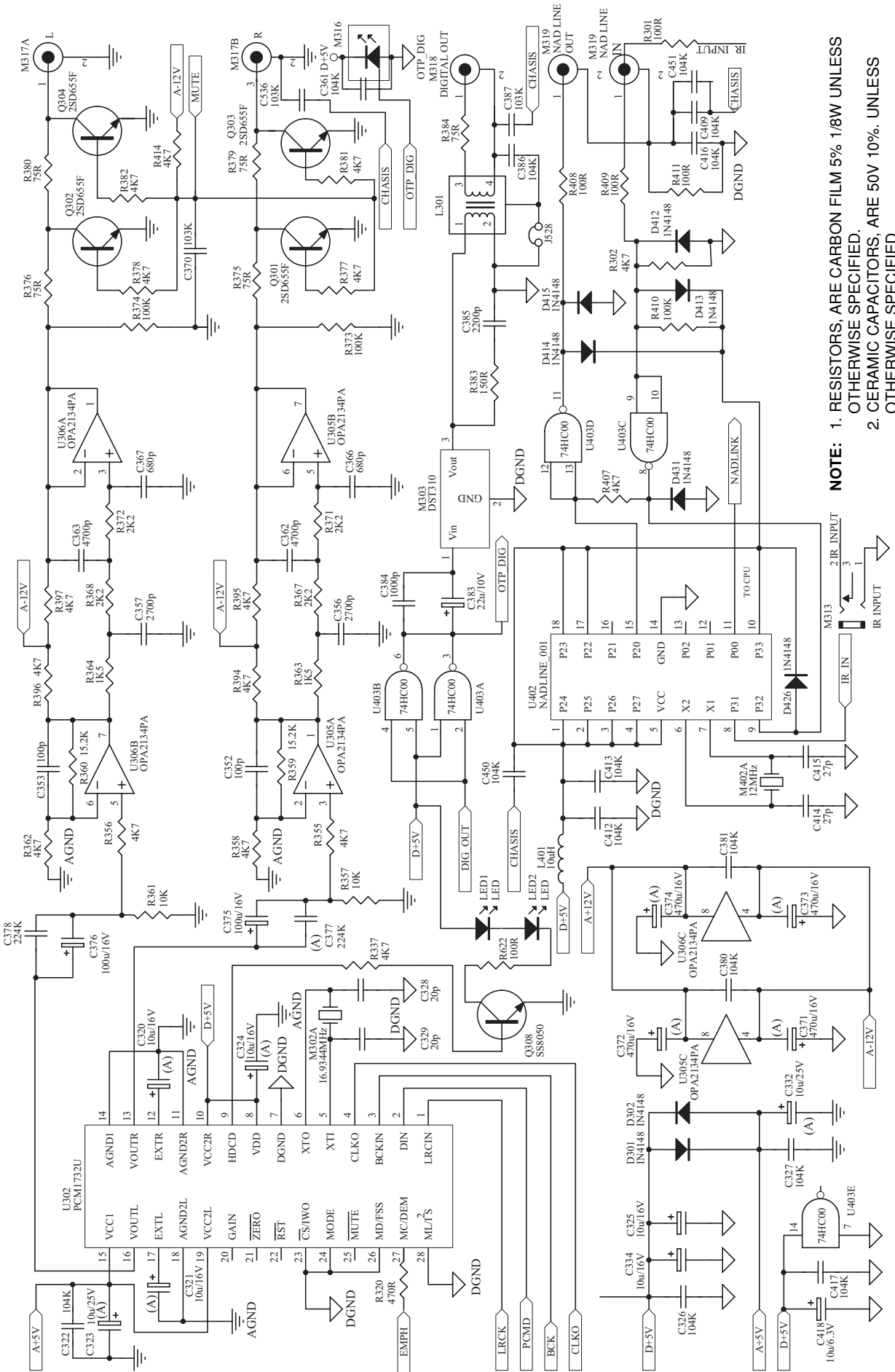

NOTE: 1. RESISTORS, ARE CARBON FILM 5% 1/8W UNLESS OTHERWISE SPECIFIED.
 2. CERAMIC CAPACITORS, ARE 50V 10%. UNLESS OTHERWISE SPECIFIED.

POWER

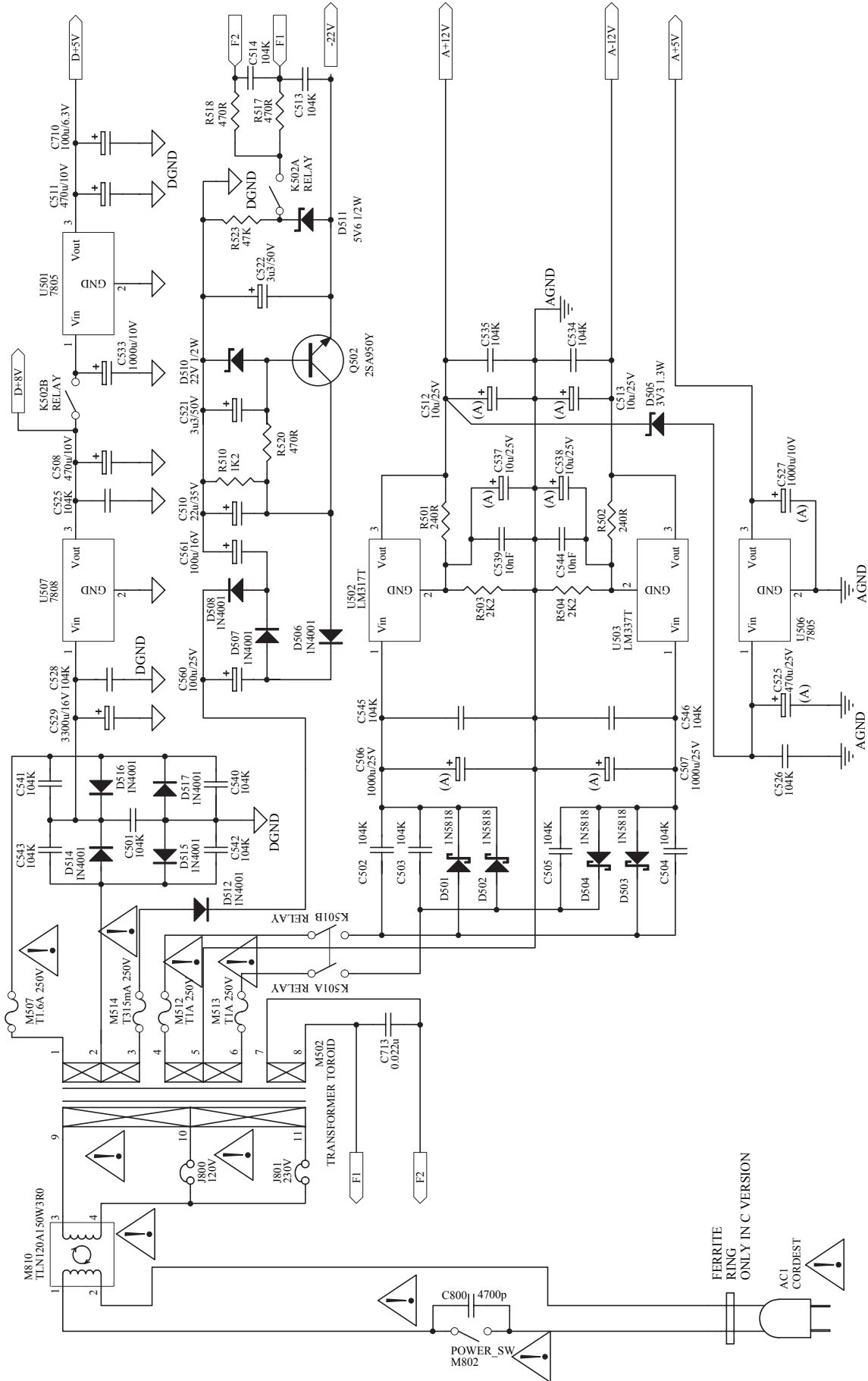

NOTE: 1. RESISTORS, ARE CARBON FILM 5% 1/8W UNLESS OTHERWISE SPECIFIED.
 2. CERAMIC CAPACITORS, ARE 50V 10%. UNLESS OTHERWISE SPECIFIED.

IC BLOCK DIAGRAM

MAIN BOARD

U101: CXA2581N

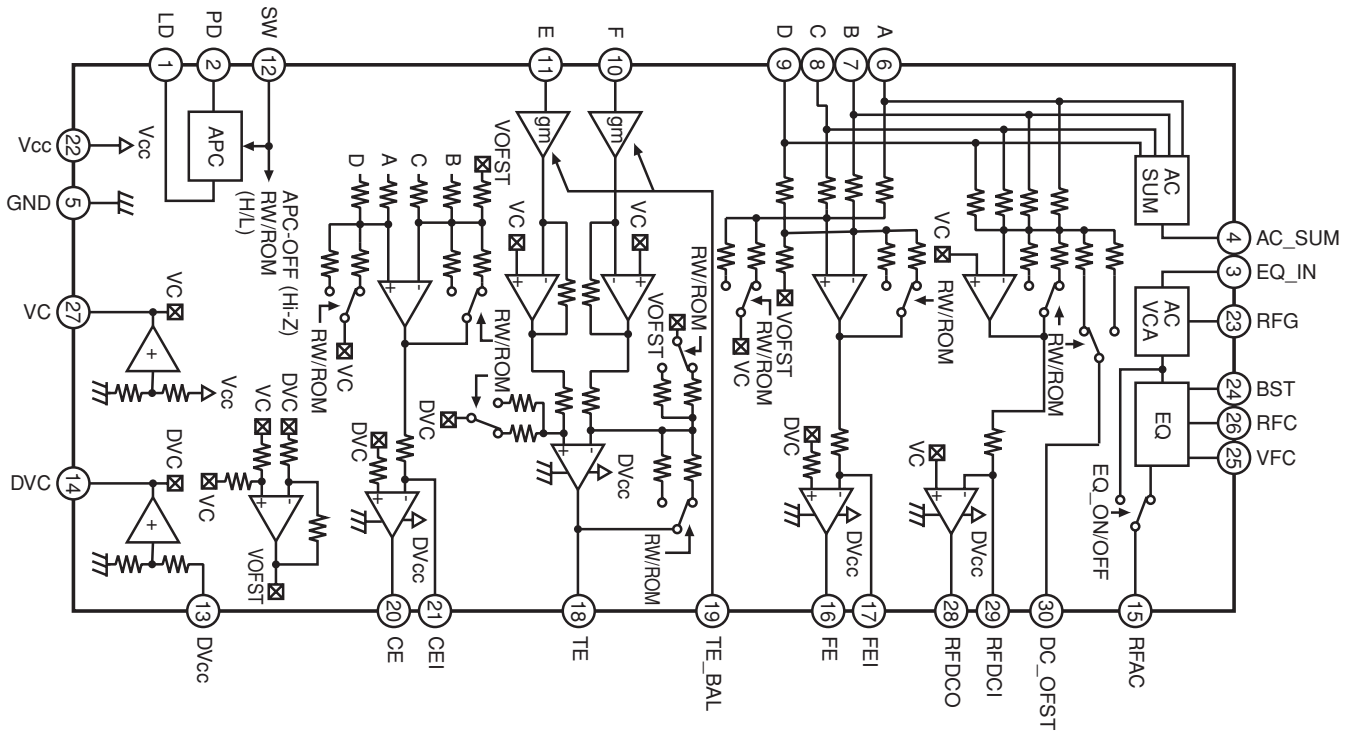

MAIN BOARD

U202: BA6392FP

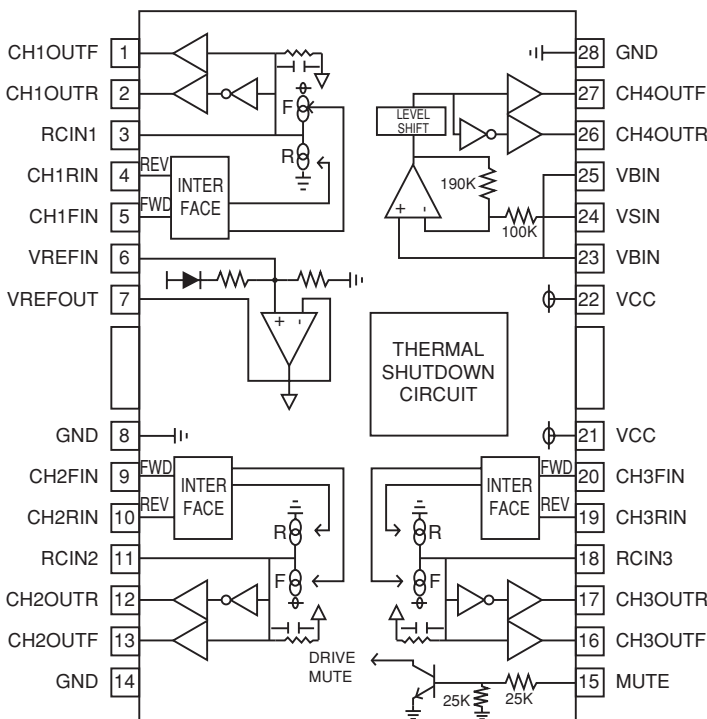

MAIN BOARD

U305, U306: OPA2134

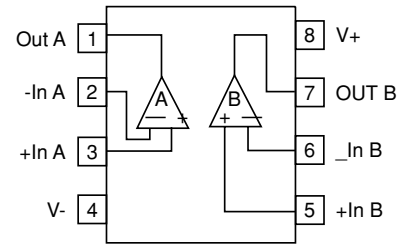

MAIN BOARD

U403: TC74HC00AP

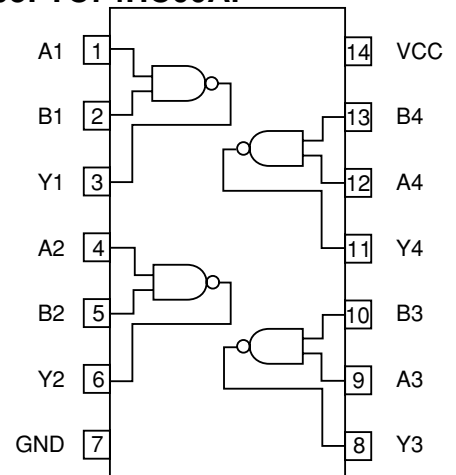

MAIN BOARD
U201: CXD3017Q

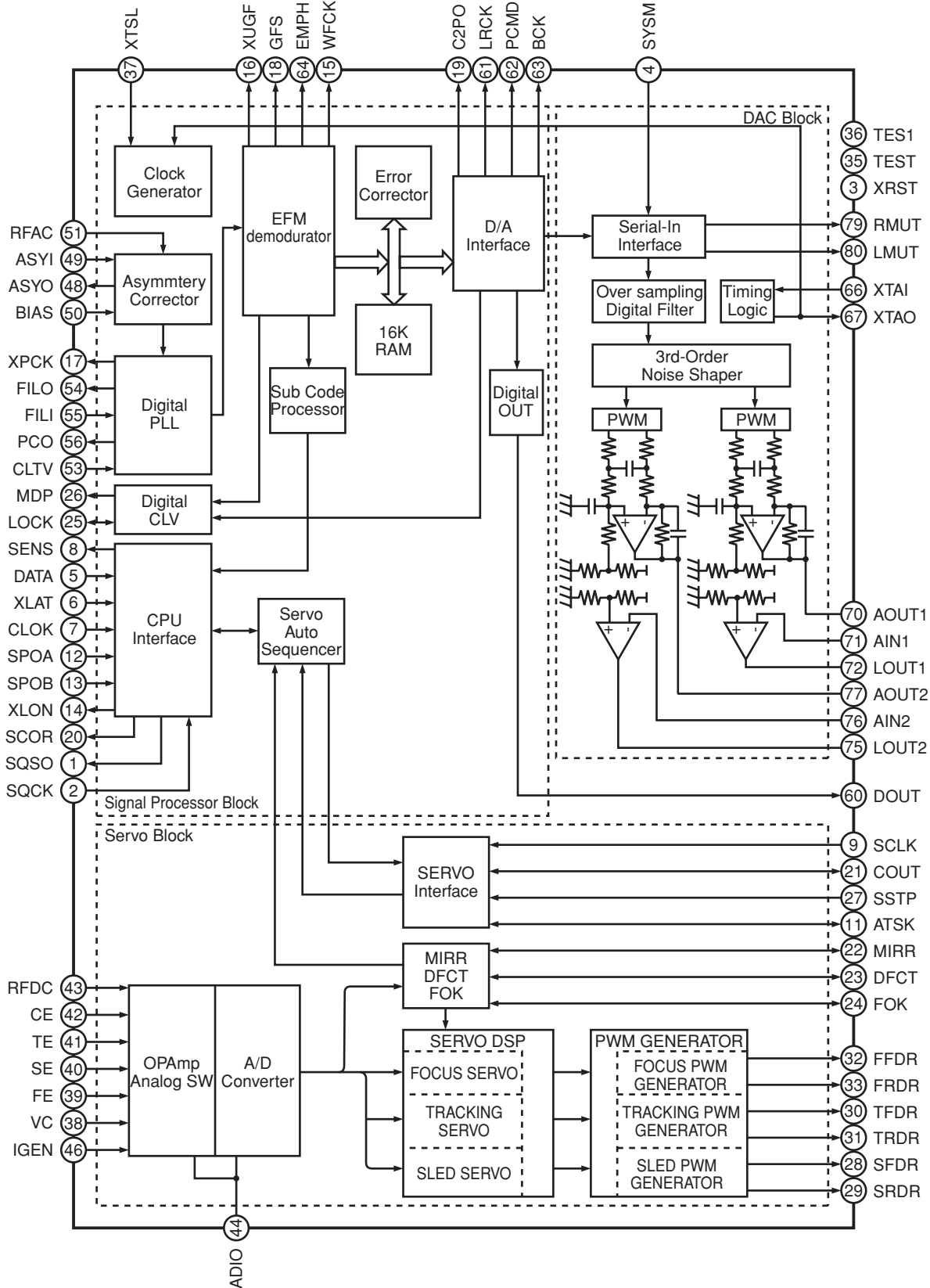

MAIN BOARD
U301: M38B57MC

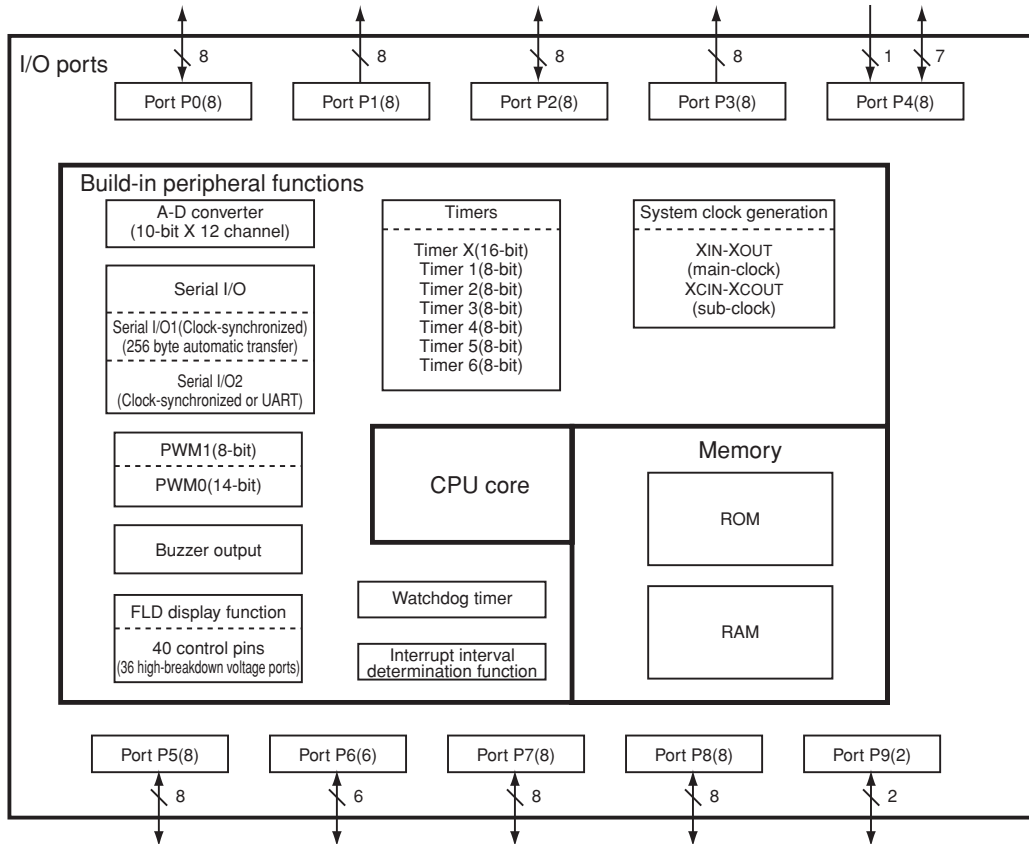
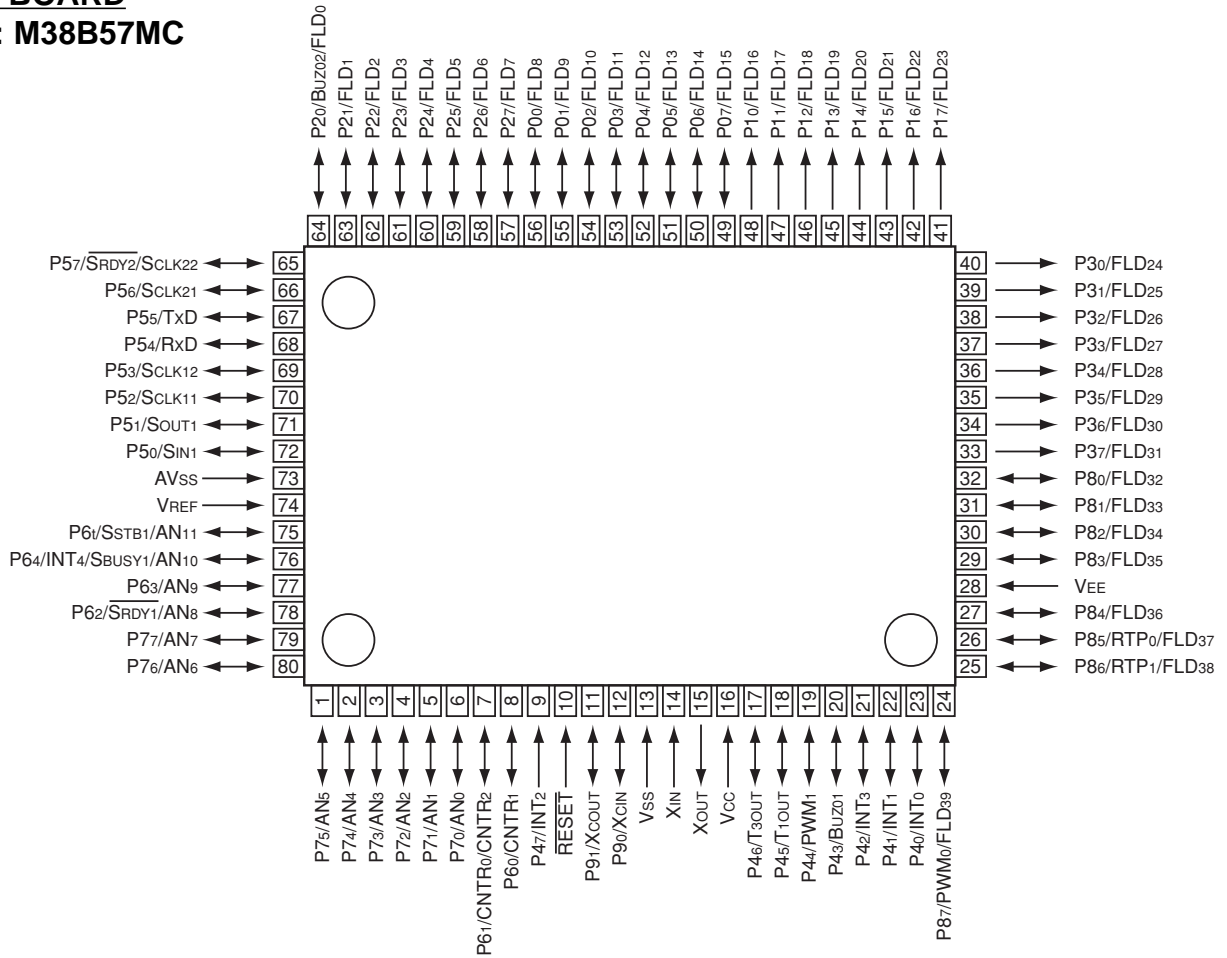

MAIN BOARD
U302: PCM1732

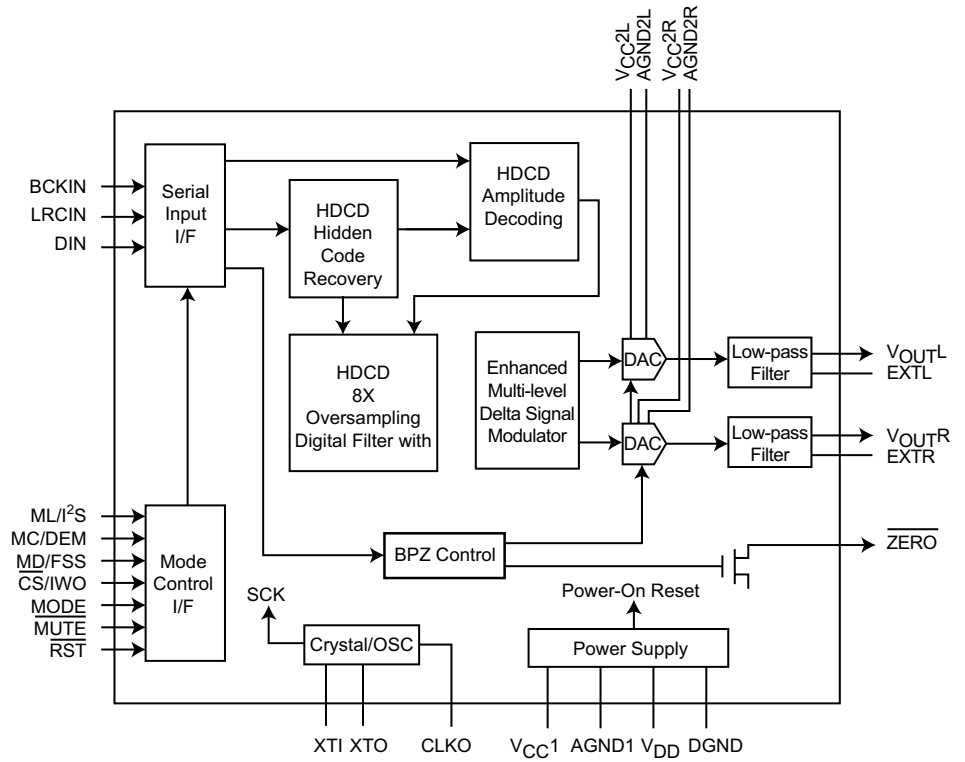
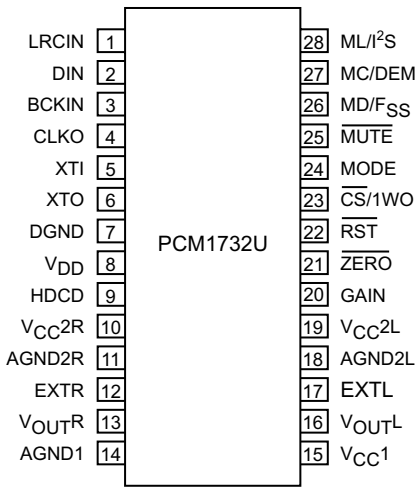

MAIN BOARD
U402: NADLINK (MASKED)

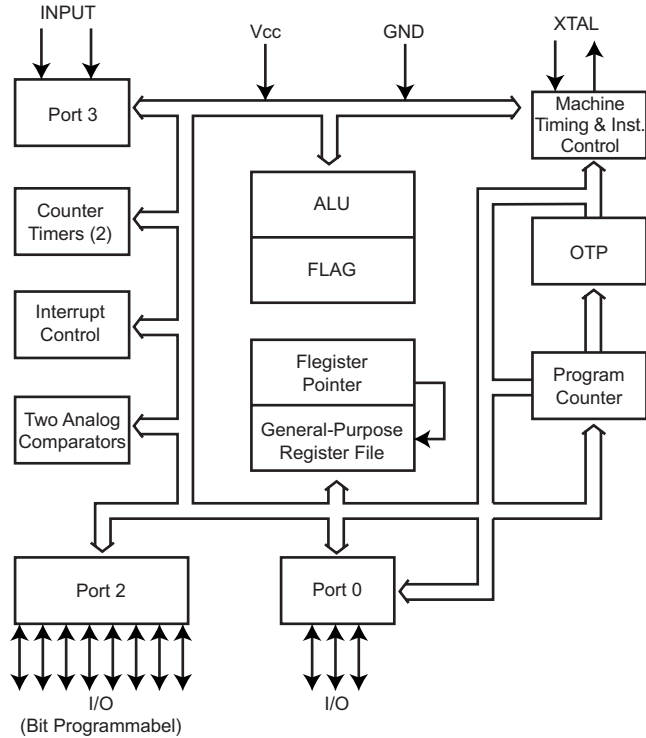
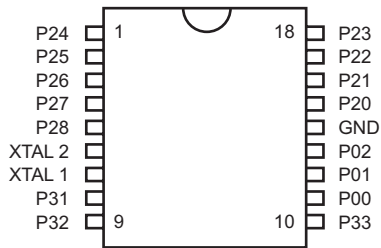

MAIN BOARD
U501, U506, U507: 78XX

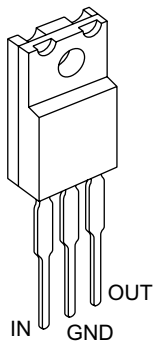

TROUBLESHOOTING GUIDE

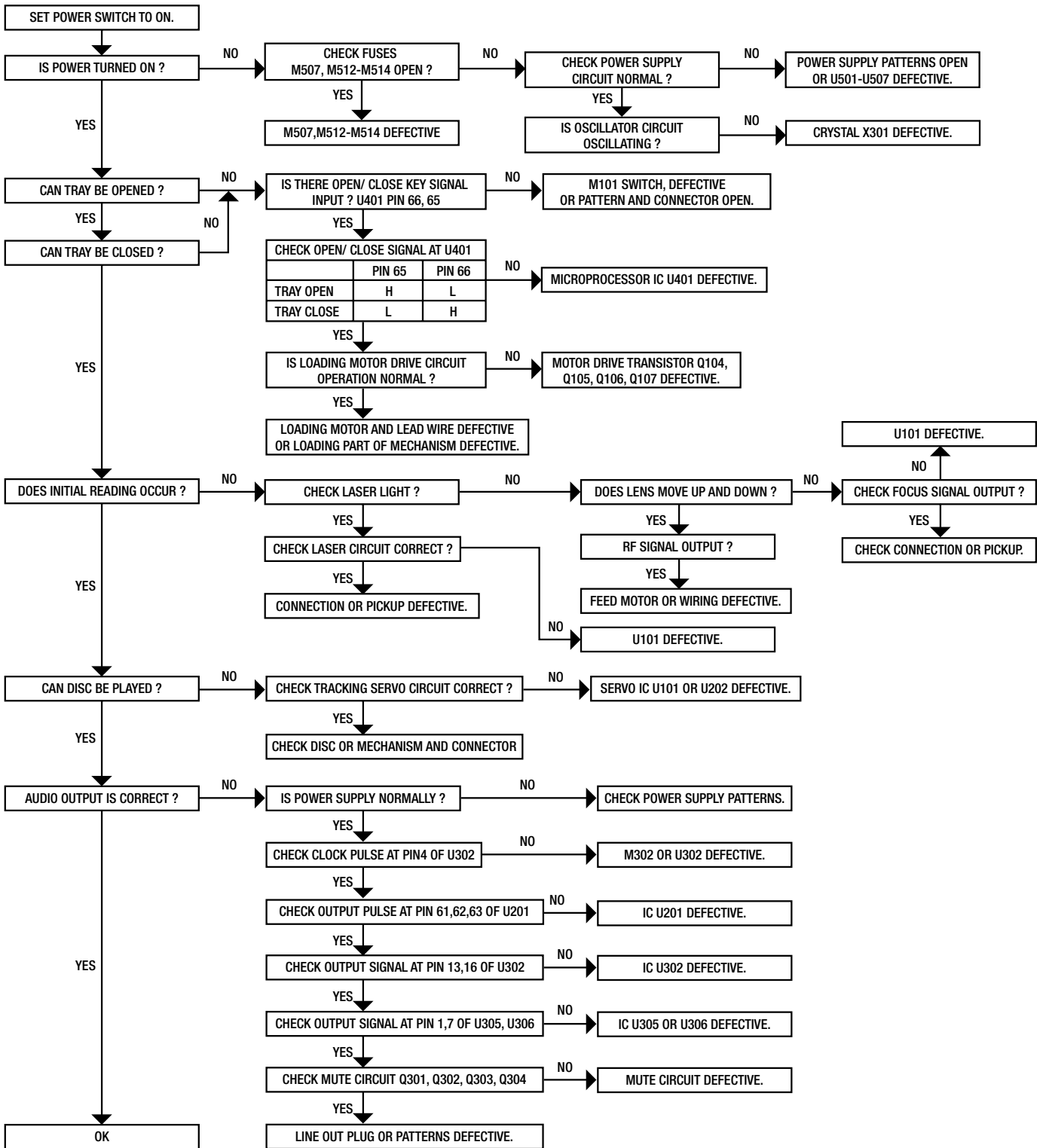

ELECTRICAL PARTS LIST

<u>Reference No.</u>	<u>Part No.</u>	<u>Description</u>
<u>DISP ASSY</u> PC BOARD	PCB-N0A70C-DISP	PCB ASSY DISP N0A70C
WIRE M505A M506A	7009-9620-0 7010-2224-0	CONN WIRE ASSY 12P 100MM CONN WIRE ASSY AWG28
PC BOARD	1725-711A-0000	PCB KEY N0A7XC C542
<u>MISCELLANEOUS</u> 0017 0024 LED1 M113 M501	4134-8701-0 4152-4841-1 3700-5810-R 4816-043T-3 2460-1870-0	HOLDER, VFD CORNER BLACK CUSHION (EL/LCD) LED RED 5X5MM RT IR SENSOR PIC-26043TM2 VFD 6-BT-271GK
<u>KEY ASSY</u> PC BOARD	PCB-N0A70C-KEY	PCB ASSY KEY N0A70C
<u>RESISTOR</u> R301,R306,R307 R302,R303 R304,R305	4701-102J-2 4701-622J-2 4701-202J-2	RCF 1/8W 1K 5% AT RCF 1/8W 6.2K 5% AT RCF 1/8W 2K 5% AT
<u>SWITCH</u> M101-M110	5200-3538-0	SWITCH, TACT SKHHBY 7MM
WIRE M120A	7012-6347-0	CONNECTOR WIRE ASSY
PC BOARD	1725-191B-0000	PCB KEY N0A70C
<u>LED ASSY</u> PC BOARD	PCB-N0A70C-LED	PCB ASSY LED N0A70C

Reference No.	Part No.	Description
LED D304	3700-3517-RG	LED RED/GREEN (L-469HGW)
WIRE M301A	7703-1280-2004	CONN.ASSY 3P P2.5 L=280
PC BOARD	1725-201B-0100	PCB MAIN N0A70C C542
LIVE ASSY PC BOARD *AH *CE	PCB-N0A70C-LIVE PCB-N0A71C-LIVE	PCB ASSY LIVE N0A70C PCB ASSY LIVE N0A71C
SWITCH M802 ▲	5200-3151-0-01	POWER SWITCH
PC BOARD	1725-201B-0100	PCB MAIN N0A70C C542
MISCELLANEOUS C800 ▲ M801,M806 M810 *CE	8910-0049-0 4132-1071-0 1806-2170-0	CAP400V 4700P TERMINAL PIN EMI FILTER TLN12UA
MAIN ASSY PC BOARD	PCB-N0A70C-MAIN	PCB ASSY MAIN N0A70C
CAPACITOR C102,C103,C207,C208,C210, C213,C217,C222,C227,C228, C304,C322,C386,C409,C412, C413,C416,C417,C450,C528 C105-C110,C230 C111 C201,C204 C203,C216,C221 C206 C209,C223 C211,C212,C414,C415 C214,C215	150F-104K-2-FC 157C-107M-5-IUE 157F-225M-5-IUNK 150F-221K-2-FC 150F-103K-2-FC 150F-331K-2-FC 153F-152J-5-JM 15CH-270J-5-GG 150F-471K-2-FC	CC 50V 0.1UF 10% AT CE 10V 100μF 20% RL 5X11 CE 50V 2.2μF 20% RL 5X11 CC 50V 220pF 10% AT 3.5x2 CC 50V 0.01μF 10% AT 3.5x2 CC 50V 330pF 10% AT 3.5x2 CM 50V 1500PF 5% RL 5.5x7 CTC 0/60 27pF 5% RL 4x4 CC 50V 470pF 10% AT 3.5x2

Reference No.	Part No.	Description
C218	150F-101K-2-FC	CC 50V 100pF 10% AT 3.5x2
C219,C220	150F-474M-5-II	CC 50V 0.47μF 20% RL 5X5
C226	157F-334M-5-GMK	CE 50V 0.33μF 20% RL 4x7
C229	157D-477M-5-OVK	CE 16V 470μF 20% RL 8x11.5
C303,C370	153F-103J-5-IM	CM 50V 0.01μF 5% RL 5X7
C305	157D-227M-5-OMK	CE 16V 220μF 20% RL 8x7
C306,C514,C515	150F-104K-5-II	CC 50V 0.1μF 10% RL 5x5
C307	157C-476M-5-IMK	CE 10V 47μF 20% RL 5X7
C308,C325,C334,C418,C420	157D-106M-5-GMK	CE 16V 10μF 20% RL 4x7
C310,C710	157B-107M-5-KMK	CE 6.3V 100μF 20% RL 6x7
C320,C321,C323,C324,C332	157D-106M-5-IUF3	CE 16V 10μF 20% RL 5X11
C328,C329	15CH-200J-5-GG	CTC 0/60 20pF 5% RL 4x4
C352,C353	158F-101J-5-KW	CP 50V 100pF 5% RL 6x12
C356,C357	153F-272J-5-JM	CM 50V 2700PF 5% RL 5.5x7
C362,C363	153I-472K-9-NL	CM 63V 0.0047μF 10% RB 7.5x6.5
C366,C367	158F-681J-5-KW	CP 50V 680pF 5% RL 6x12
C371-C374,C527	157D-477M-5-X9F3	CE 16V 470μF 20% RL 12.5x20
C375,C376	157E-107M-5-S5C	CE 25V 100μF 20% RL 10x16
C377,C378	153I-224J-9-NL	CM 63V 0.22μF 5% RB 7.5x6.5
C383	157C-226M-5-IUK	CE 10V 22μF 20% RL 5X11
C384	150F-102K-2-FC	CC 50V 1000pF 10% AT 3.5x2
C385	150F-222K-2-GD	CC 50V 0.0022μF 10% AT
C387,C419,C539,C544	153F-103K-5-IM	CM 50V 0.01μF 10% RL 5x7
C407	157D-228M-5-X9E	CE 16V 2200μF 20% RL 12.
C506,C507	157E-108M-5-5\$F3	CE 25V 1000μF 20% RL 12.5x20
C508,C533	157C-108M-5-S5K	CE 10V 1000μF 20% RL 16x31.5
C510	157F-107M-5-OVK	CE 50V 100μF 20% RL 10x16
C511	157C-227M-5-OMK	CE 10V 220μF 20% RL 8x7
C512,C513,C537,C538	157E-106M-5-IUF3	CE 25V 10μF 20% RL 5X11
C521	157F-226M-5-IUK	CE 50V 22μF 20% RL 5X11
C522	157Q-476M-5-LUA	CE 35V 47μF 20% RL 6.5X11
C525	157C-108M-5-X&F3	CE 10V 1000μF 20% RL 12.5x25
C529	157D-338M-5-5&K	CE 16V 3300μF 20% RL 16x25
C560	157E-107M-5-KUK	CE 25V 100μF 20% RL 6.3x11
C561	157D-107M-5-KUK	CE 16V 100μF 20% RL 6.3x11
C713	153F-223K-5-LQ	CM 50V 0.022μF 10% RL 6.5x9
COIL		
L101,L102,L302	1801-100K-M	COIL 10μH 10% BL7.0
L201	1801-270K-M	COIL 27 μH,10%,AL,BL7
L301	1802-0450-0	DIGITAL COIL
WAFER/CONNECTOR		
M102	2101-1382-0	CONNECTOR FLEXIBLE 16P
M120B	2102-051S-004	5P ST.WAFER

Reference No.	Part No.	Description
M301B	2102-031S-004	3 PIN ST. WAFER
M502	2101-1811-0	8P PIN CONNECTOR P=3.96
M505B	2102-121S-004	12P ST.WAFER
M506B	2102-161S-004	16P ST WAFER P=2.5
JACK		
M313,M315	2113-1743-0	MONO JACK HTJ-035-12E
M317	2113-1300-0	2P RCA JACK W/R AU
M318	2113-1170-0	1P RCA JACK YL AU
M319	2113-1121-0	2P RCA JACK Y/Y AU
CRYSTAL		
M302	2300-1910-0	X'TAL 16.9344MHZ
SCREW		
	2954-2608-3000	SCREW BT 2.6X8 BLACK
	2954-3008-0000	TAPPING 3X8MM B-TITE
IC		
U101	3131-8030-0	IC CXA2581N ASP FOR CD S
U201	3131-8000-0	IC CXD3017Q DSP FOR CD
U202	3131-8040-0	IC BA6392FP 4-CHANNEL
U301	3131-8010-1	IC M38B57MC MICRO MASK
U302	3131-9380-0	IC PCM1732 HDCD DIA
U305,U306	3131-7620-0	IC OPA2134PA DIP OP AMP
U402	3130-9320-0	IC NADLINK (MASKED)
U403	3130-4160-0	IC TC74HC00AP DIGITAL
U501,U506	3130-2020-3	IC 7805 REG 5V 1.5A
U502	3130-5610-0	IC LM317T+ADJ REGULATOR
U503	3130-5620-0	IC LM337T-ADJ REGULATOR
U507	3130-2790-1	IC NJM7808FA +8V REG
RELAY		
K501,K502	4500-0200-1	RELAY 2P2T BT-12S 12VDC
RESISTOR		
	4701-100J-2	RCF 1/8W 10R 5% AT
J178,R227,R3,R408,R409,R411	4711-101A-2	RMF 1/8W 100R 1% AT
R1,R111,R201,R316,R327,R328, R329,R331,R333,R334,R337, R355,R356,R358,R362,R377, R378,R381,R382,R394,R395, R396,R397,R407,R412	4711-472A-2	RMF 1/8W 4.7K 1% AT
R103,R104	4711-203A-2	RMF 1/8W 20K 1% AT

Reference No.	Part No.	Description
R105,R110,R30-R310	4711-302A-2	RMF 1/8W 3K 1% AT
R106	4711-154A-2	RMF 1/8W 150K 1% AT
R107,R212,R220,R225,R311, R373,R374,R410,R414	4711-104A-2	RMF 100K 1/8W 1% AT
R108	4711-683A-2	RMF 1/8W 68K 1% AT
R109,R119,R218,R219,R322	4711-153A-2	RMF 1/8W 15K 1% AT
R112,R113,R114	4711-512A-2	RMF 1/8W 5.1K 1% AT
R115	4711-182A-2	RMF 1/8W 1.8K 1% AT
R116,R117	4711-123A-2	RMF 1/8W 12K 1% AT
R118,R213,R224,R230,R312, R321,R335,R336,R338,R357, R361,R403	4711-103A-2	RMF 1/8W 10K 1% AT
R121-R124,R202-R207, R209-R211,R217,R315,R317, R332,R402	4711-102A-2	RMF 1/8W 1K 1% AT
R125,R215	4701-4R7J-C	RCF 1/8W 4.7R 5% ATS
R214	4711-822A-2	RMF 1/8W 8.2K 1% AT
R223	4711-333A-2	RMF 1/8W 33K 1% AT
R226	4711-105A-2	RMF 1/8W 1M 1% AT
R228,R229	4711-332A-2	RMF 1/8W 3.3K 1% AT
R318,R320,R517,R518,R520	4711-471A-2	RMF 1/8W 470R 1% AT
R319	4711-561A-2	RMF 1/8W 560R 1% AT
R359,R360	4711-1522-2	RMF 1/8W 15.2K 1% AT
R363,R364	4711-152A-2	RMF 1/8W 1.5K 1% AT
R367,R368,R371,R372,R503,R504	4711-222A-2	RMF 1/8W 2.2K 1% AT
R375,R376,R379,R380,R384	4711-750A-C	RMF 1/8W 75R 1% ATS
R383	4711-151A-C	RMF 1/8W 150R 1% ATS
R405	4711-223A-2	RMF 1/8W 22K 1% AT
R406,R415	4711-752A-2	RMF 1/8W 7.5K 1% AT
R413,R416,R523	4711-473A-2	RMF 1/8W 47K 1% AT
R501,R502	4711-241A-2	RMF 1/8W 240R 1% AT
DIODE		
	4804-0010-2	DIODE 1N4001 AT
D301-D303,D307,D308,D404, D409,D411-D415,D426,D431	4804-1480-2	DIODE 1N4148 AT
D305	4805-3930-2	DIODE 1N5393 200V 1.5A
D403	4837-3V36-2	DZ 1/2W +-5% 3.3V TEMIC
	4837-5B61-2	DZ 1/2W 5.45-5.73 ROHM
D501-D504	4808-18R0-2	DIODE IN5818R-ND AT
D505	4840-1140-0	ZD 1.3W 3.3V 5% AT
D510	4837-22D1-2	DZ 1/2W 21.52~22.63V

Reference No.	Part No.	Description
TRANSISTOR		
Q101,Q104,Q105	4860-0060-5	TR SS8550 C/D SAMSUNG RL
Q103,Q106,Q107,Q307-Q312	4860-0050-5	TR SS8050 C/D SAMSUNG RL
Q301-Q304	4860-1780-5	TR 2SD655F HFE:600-1200
Q401,Q403	4860-0660-5	TR 2SA1015 (G.R.) RL
Q402	4851-012F-5	TR 2SD1012F/G HFE
Q404	485A-114E-5	TR DTA114ESA ROHM
Q405	485C-114E-5	TR DTC114ES
Q502	485A-950Y-5	TR 2SA950-Y HFE 100-200
SWITCH		
M314	5200-3171-0-01	DPDT SLIDE
HEATSINK		
U501-U503,U506,U507	5400-9130-0	HEAT SINK FOR 7805 2438-
WIRE		
M101	7012-6536-0	CONN WIRE ASSY 5PIN P2.0
M102C	7012-6232-0	WIRE CON 16P P=1.0
M105A	7012-6538-0	CONN WIRE ASSY 6PIN P2.0
PC BOARD		
	1725-201B-0100	PCB MAIN N0A70C C542
MISCELLANEOUS		
GND1	4132-1061-0	SOLDER TAG
M302	4152-9052-0	CRYSTAL CUSHION (BOTTOM)
M302	4152-9042-0	CRYSTAL CUSHION (TOP)
M303	2704-0060-0	EMC FILTER
M316	4811-F32T-3	LIGHT TX UNIT GP1F32T
M402	2703-0190-0	CR RESONATOR
M507,M512,M513,M514	4131-9131-0	FUSE HOLDER 6.5MM PITCH
U502,U503	2601-2608-0601	FIBRE WASHER M2.6 0.8T
	2703-0150-1	CR4.00MHE,CSTLS4M00G55-B

- NOTE:**
- The components identified by \triangle mark are critical for risk of fire and electrical shock. Replace only with part number specified.
 - <*AH > : USA, Canadian model only.
 - <*C > : European model only.
 - Capacitors : CP-Polystyrene, CM-Mylar, CE-Electrolytic, CC-Ceramic, CTC-NPO.
 - Resistors : RMF-Metal Film, RCF-Carbon Film, RWR-Wirewound Metal Oxide.

MECHANISM EXPLODED VIEW

WSL-2130CCM

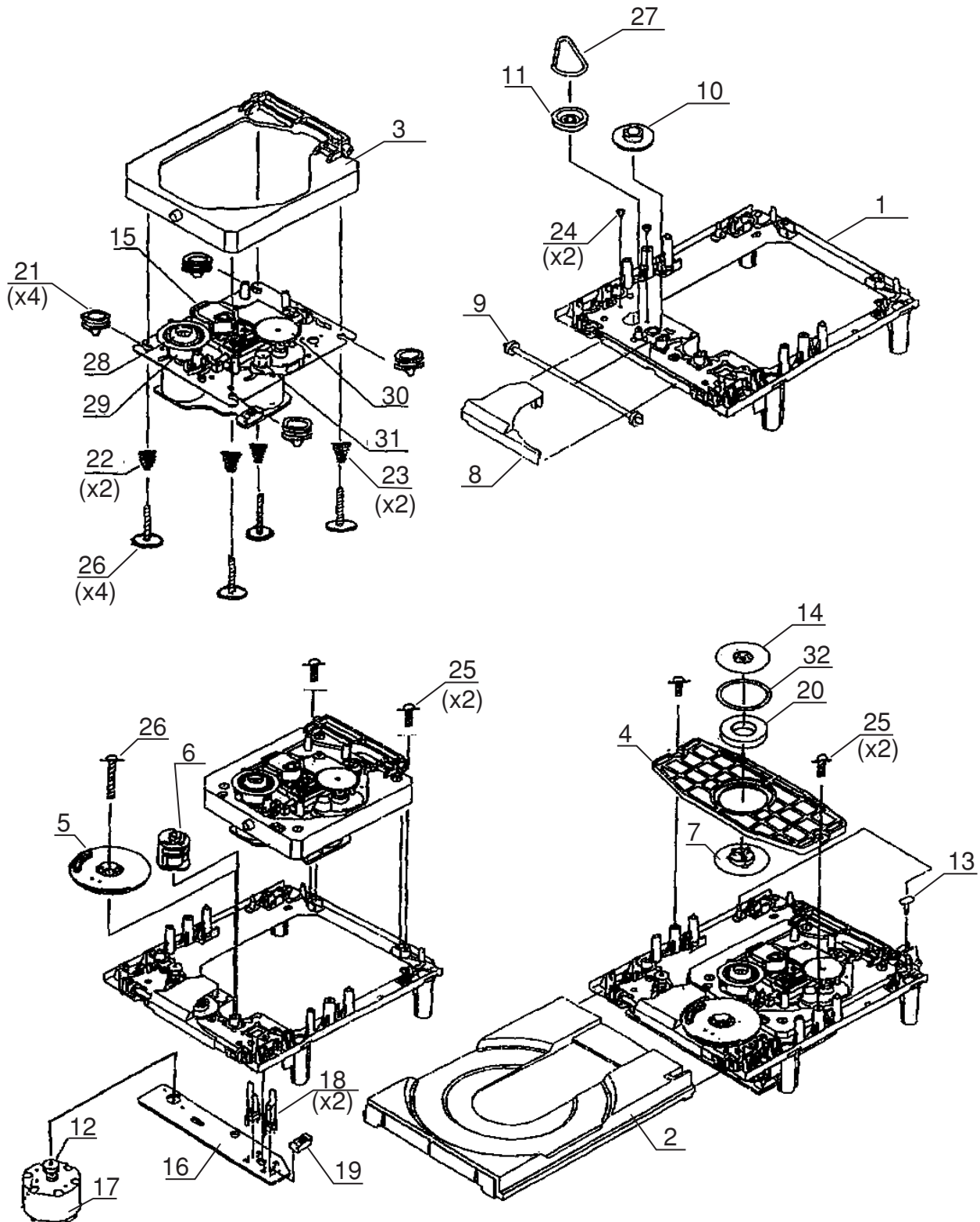

MECHANISM EXPLODED VIEW PARTS LIST

Item	Part No.	Description	Qty
1	4102-9000-0	Outside Main Chassis	1
2	4102-9001-0	Tray	1
3	4102-9002-0	Subchassis	1
4	4102-9003-0	Chucking Plate	1
5	4102-9004-0	Drive Gear	1
6	4102-9005-0	Control Cam	1
7	4102-9006-0	Chucking Pulley	1
8	4102-9007-0	Gear Cover	1
9	4102-9008-0	Tray Gear	1
10	4102-9009-0	Intermediate Gear	1
11	4102-9010-0	Loading Pulley	1
12	4102-9011-0	Motor Pulley	1
13	4102-9012-0	SW Pin	1
14	4102-9013-0	Chucking Yoke	1
15	4102-9014-0	Optical Pickup Unit	1
16	4102-9015-0	Loading PWB	1
17	4102-9016-0	Motor RF-500TB-14415	1
18	4102-9017-0	Leaf Switch	1
19	4102-9018-0	Connector pin (5P)	1
20	4102-9019-0	Magnet	1
21	4102-9020-0	Insulator	4
22	4102-9021-0	Coil Spring (Front)	2
23	4102-9022-0	Coil Spring (Rear)	2
24	4102-9023-0	Screw-Motor M2.6x2.5	2
25	4102-9024-0	Screw M2.6x7	2
26	4102-9025-0	Screw Washer Based M2.6x16	4
27	4102-9026-0	Rubber Belt	1
28	4102-9027-0	Center Ring	1
29	4102-9028-0	Turn Table	1
30	4102-9029-0	Gear (A)	1
31	4102-9030-0	Motor Gear	1
32	4102-9031-0	Damper	1

EXPLODED VIEW

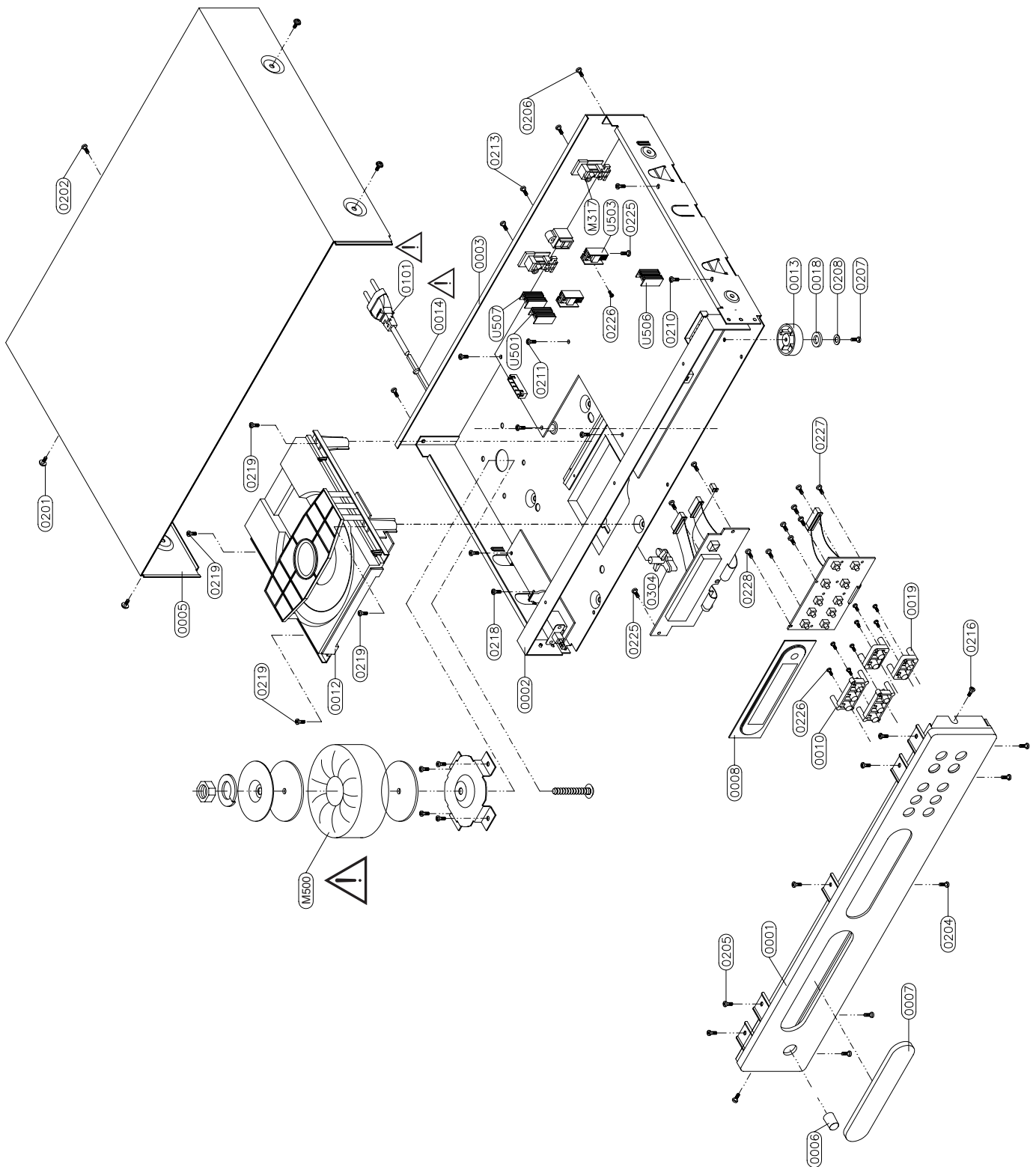

EXPLODED VIEW PARTS LIST

Item	Part No.	Description
0001 *AH GREY/*CE GREY	1466-5103-0	FASCIA BLACK (C542)
0001 *AH TI/*CE TI	1466-5104-1	FASCIA SILVER (C542)
0002	1402-3783-2	STRAP (C542)
0003 *AH GREY/*AH TI	1402-3526-1	CHASSIS C542(AH)
0003 *CE GREY/*CE TI	1402-3527-1	CHASSIS C542(C)
0005 *AH GREY/*CE GREY	1402-3531-0	TOP COVER BLACK (C542)
0005 *AH TI/*CE TI	1402-3532-0	TOP COVER SILVER (C542)
0006 *AH GREY/*CE GREY	2442-1002-0	POWER BUTTON BLACK
0006 *AH TI/*CE TI	2442-1003-0	POWER BUTTON SILVER
0007 *AH GREY/*CE GREY	4154-4192-1	CD DOOR BLACK (C521BEE)
0007 *AH TI/*CE TI	4154-4194-1	CD DOOR SILVER (C521BEE)
0008	3716-4318-0	WINDOW LENS C542
0010 *AH GREY/*CE GREY	2444-1203-0	BUTTON TRIO BLACK
0010 *AH TI/*CE TI	2444-1204-0	BUTTON TR10 TITANIUM
0013	4157-0501-1	RUBBER FOOT
0014 \triangle	4151-9461-0	STRAIN RELIEF BUSHING
0018	4152-4641-1	CUSHION FOOT W/RUBBER WA
0019 *AH TI/*CE TI	2444-1904-0	DUO BUTTON TITANIUM
0019 *AH GREY/*CE GREY	2444-1903-0	DUO BUTTON BLACK
0024	3714-5706-0	LED LENS (412) CLEAR SAN
0027	4104-3721-0	TRANSFORMER BRACKET
0101 *AH GREY/*AH TI \triangle	7009-3100-2	AC CORD 18AWGX2
0101 *CE GREY/*CE TI \triangle	7009-3110-0	AC CORD (SEMKO)
0102 *CE GREY/*CE TI	1808-0130-0	FERRITE CODE D19XT10
0201 *AH TI/*CE TI	2900-4006-2010	SCM PW M4X6 RECESS WHITE
0201 *AH GREY/*CE GREY	2900-4006-3010	M4X0.5PX6MM W/FLAT
0202 *AH TI/*CE TI	2954-3010-4000	ST SCREW 3X10 BH
0202 *AH GREY/*CE GREY	2954-3008-3000	T3X8MM SELF TAPPING
0204	2954-3008-3000	T3X8MM SELF TAPPING
0205	2954-3008-0000	TAPPING 3X8MM B-TITE
0206	2954-3008-3000	T3X8MM SELF TAPPING
0207	2954-3008-3000	T3X8MM SELF TAPPING
0208	2842-3367-0	METAL WASHER
0209	2900-4006-3010	M4X0.5PX6MM W/FLAT
0210	2954-3008-0000	TAPPING 3X8MM B-TITE

Item	Part No.	Description
0211	2904-3006-0000	SCREW M3X6
0213	2954-3008-3000	T3X8MM SELF TAPPING
0216	2954-3008-0000	TAPPING 3X8MM B-TITE
0218	2954-3008-0000	TAPPING 3X8MM B-TITE
0219	2904-3006-3000	SCREW M3X6 BINDING (BLK)
0225	2954-3008-0000	TAPPING 3X8MM B-TITE
0226	2954-2006-0000	TAPPING SCREW 2X6
0227	2954-2608-0000	SCREW BT 2.6X8
0228	2600-4008-0973	FLAT WASHER M4X0.8X9.7
	2601-3004-0801	FIBRE WASHER
0230	2954-3008-0000	TAPPING 3X8MM B-TITE
0301	4151-9411-0	CUSHION 130X10X1MM
0304	1463-160B-1	CD TRANSIT LOCK (ED)
0309	3100-5101-0	PC SHEET 50X7X0.25
0311	4152-0241-0	PAD CORK 15X12X3MM GRAY
0315	3100-5101-0	PC SHEET 50X7X0.25
0316	4154-1371-0	PC SHEET 14X260X0.5 THK
0500 *AH GREY/*AH TI	3000-4290-0	LABEL, BLANK 45X10
0500 *AH GREY/*AH TI	3005-0360-2	RIBBON 60MMX600M TEC
0501	3009-1689-0	CD LASER LABEL YELLOW
0502	3000-4205-0	LABEL, CD WARNING
M500 	1806-2512-0	TRANSFORMER N0870C I/P

- NOTE:**
- The components identified by  mark are critical for risk of fire and electrical shock. Replace only with part number specified.
 - <*AH > : USA, Canadian model only.
 - <*C > : European model only.

PACKING DIAGRAM

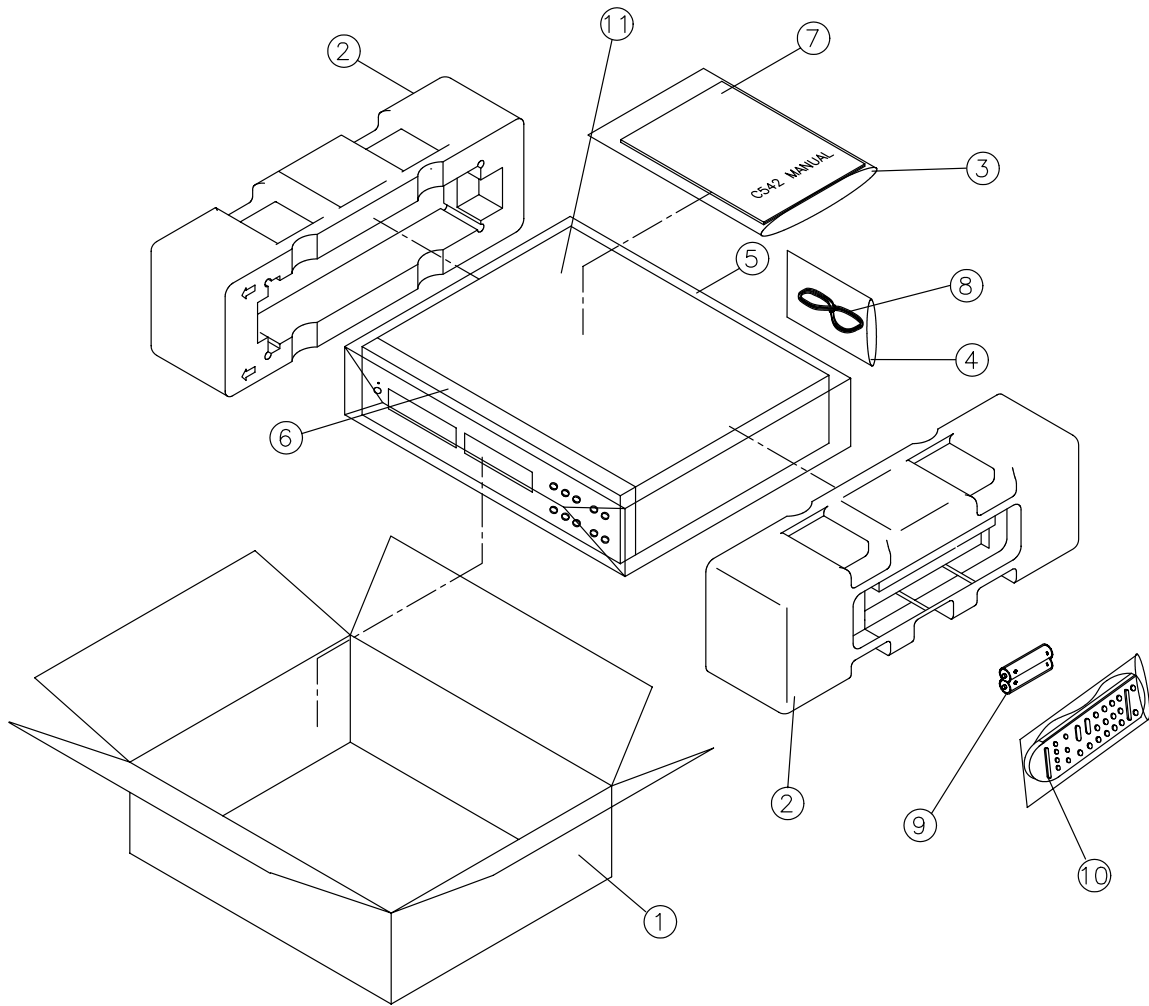

ITEM	PART NO.	DESCRIPTION	Q'TY
1.	1435-8401-0-2	CARTON BOX C542	1
2.	1490-3783-2	POLYFORM ENDCAP	2
3.	1497-1062-0	POLYBAG MANUAL	1
4.	1497-1302-0	POLYBAG	1
5.	1497-1332-1	POLYBAG	1
6.	1497-1432-0	EPE BAG (412)	1
7.	4301-7073-0	INSTRUCTION MANUAL	1
8.	2103-7302-1	RCA PLUG (MALE)	1
9.	4060-0530-0	GREENCELL 3A SIZE GP24G2	2
10.	8912-0038-0	REMOTE CONTROL C521BEE	1
11.	1405-2520-0	WHITE PAPER	1

Proprietary information for servicing purposes only. The information herein may not be used commercially without the prior written agreement of NAD Electronics International, Toronto, Canada.

SERVICE MANUAL

C 542

COMPACT
DISC PLAYER

© NAD 2003

NAD ELECTRONICS INTERNATIONAL
TORONTO